

## Horizontal Form Fill Seal Machine CDS-180

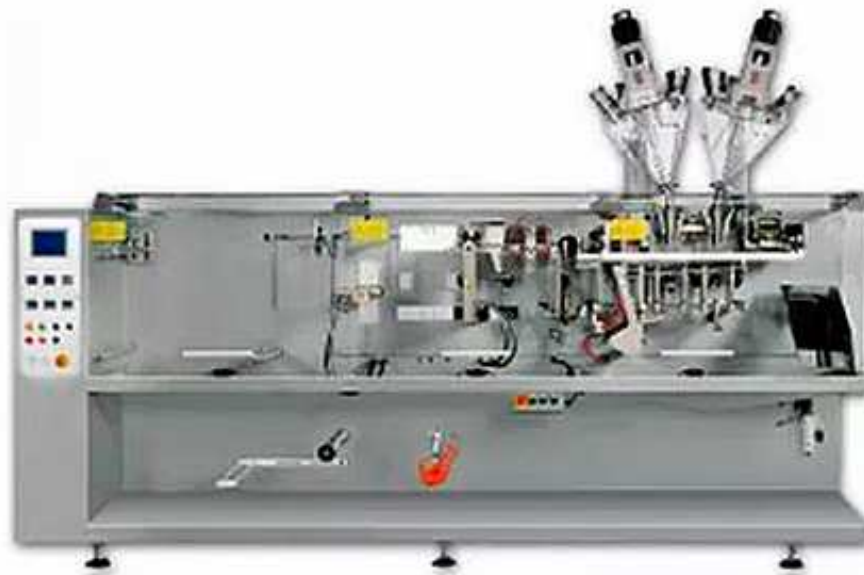

### Features

- With touch screen to display machine state, operation instruction, the state of breakdown.
- High reliable PLC control.
- Equipped with a photocell made in Germany avoiding film-cutting error.
- Connected parts with product made by stainless steel.
- Various of feeding system. (Servo Spiral, Measuring cup, Plunger pump, Gravity Feeder, Hibar Pump, Combination Weigher)

### Bag Range

- L60~180\*W80~225mm

### Seal Type

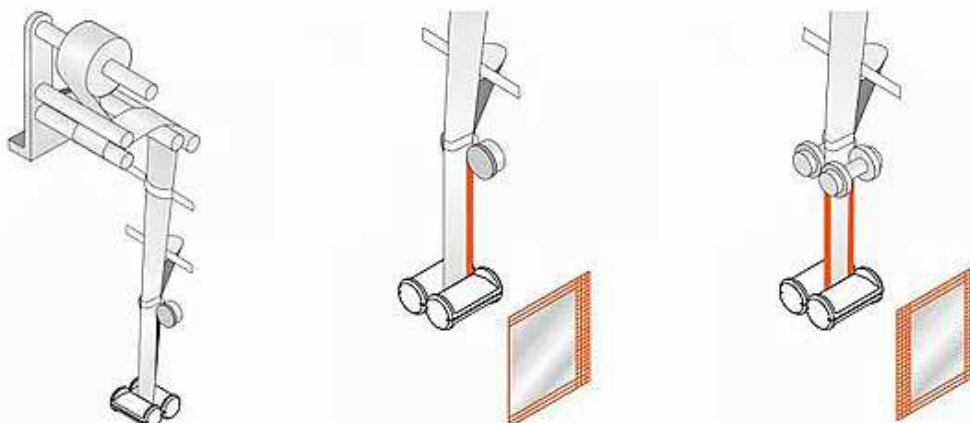

## Specification

Model	CDS-180
Feeding Station	2
Pouch Format	Flat
Packing Style	3-side seal/4-side seal
Pouch Material	Any Laminated Heat Sealable, ex.PET/OPP, PET/OPP
Max. Film Diameter	Max. 500 mm
Pouch Size	60*80mm ~ 180*220mm
Pouch Capacity	360 ml
Operating Speed	70ppm
Power Supply	380V 3 Phase 50Hz
Weight	Approx. 1000KG
Machine Size	3500*970*1470 mm

## Optional Device

- tear notch
- minus shaped east tear