

PR-3000 Series Rotary Tablet Press



The PTK rotary tablet press model, PR-3000 series is designed especially for symmetry, with its space saving octagon shape. Composed of a rigid frame with smart interior it is totally accessible for ease of cleaning and maintenance.

In addition to this, the control screen is self contained and accessible. The PR-3000 guarantees a plentiful output and is designed to produce tablets in an efficient double sided configuration.

Layout Drawing

- | | | |
|----------------------------|-----------------------------|--|
| — 1.Main Machine | — 4.Dust Collector (option) | — 7.IFH - Impeller Feeding Hopper (option) |
| — 2.Control Cabinet | — 5.Deduster (option) | — 8.Turret Table - 2set (option) |
| — 3.Powder Loader (option) | — 6.Metal Detector (option) | |

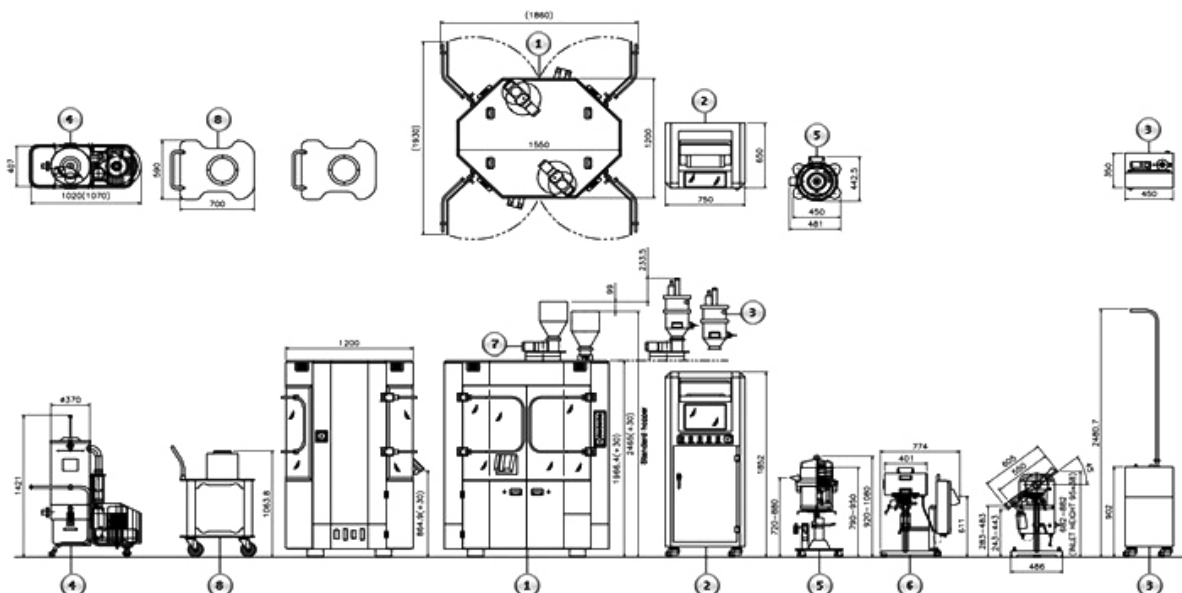

Specification				
Number of Punch Stations	43	52	63	68
Punch / Die type	<i>D</i>	<i>B</i>	<i>BB</i>	<i>BBS</i>
Max. Main Compression Force	<i>100 kN</i>	<i>100 kN</i>	<i>100 kN</i>	<i>100 kN</i>
Max. Pre Compression Force	<i>100 kN</i>	<i>100 kN</i>	<i>100 kN</i>	<i>100 kN</i>
Max. Output	<i>309,600 tabs/h</i>	<i>436,800 tabs/h</i>	<i>529,200 tabs/h</i>	<i>571,200 tabs/h</i>
Max. Filling Depth	<i>18 mm</i>			
Max. Tablet Thickness	<i>8.5 mm</i>			
Upper Punch Insert	<i>1 - 4 mm (1 - 8 mm incase of double layer)</i>			
Pitch Circle Diameter	<i>615 mm</i>			
Turret Speed	<i>5 - 60 rpm</i>	<i>5 - 70 rpm</i>	<i>5 - 70 rpm</i>	<i>5 - 70 rpm</i>
Max. Tablet Diameter (round)	<i>25 mm</i>	<i>16 mm</i>	<i>13 mm</i>	<i>11 mm</i>
Max. Tablet Diameter (shape)	<i>25 mm</i>	<i>19 mm</i>	<i>14 mm</i>	<i>12 mm</i>
Machine Dimension	<i>1,550 * 1,200 * 1,900 mm</i>			
Cabinet Dimension	<i>750 * 650 * 1,850 mm</i>			
Maching Weight	<i>6,000 kg</i>			
Cabinet Weight	<i>140 kg</i>			
Power Supply Data	<i>220/380 Vac 3Ph 50/60 Hz</i>			
Control Power	<i>24 Vdc</i>			
Double Layer Max. Output	<i>103,200 tabs/h</i>	<i>156,000 tabs/h</i>	<i>189,000 tabs/h</i>	<i>204,000 tabs/h</i>