

## Horizontal Form Fill Seal Machine HD-180D



### Features

- High-speed automatic splicer.
- Electronic cam servo package tractor.
- High reliable PLC control.
- With touch screen to display machine state, operation instruction, the state of breakdown.
- Keyence photoelectric color detector.
- Trio Motion Controllers.
- Camozz pneumatic control components.
- SMC Cylinder.
- Electronic cam servo device for small vehicles.
- Automatic control for material position.
- With safety switch and guard design.
- Connected parts with product made by stainless steel.
- Various of feeding system. (Servo Spiral, Measuring cup, Plunger pump, Gravity Feeder, Hibar Pump, Combination Weigher)

### Bag Range

- L50~90\*W60~140mm

### Seal Type

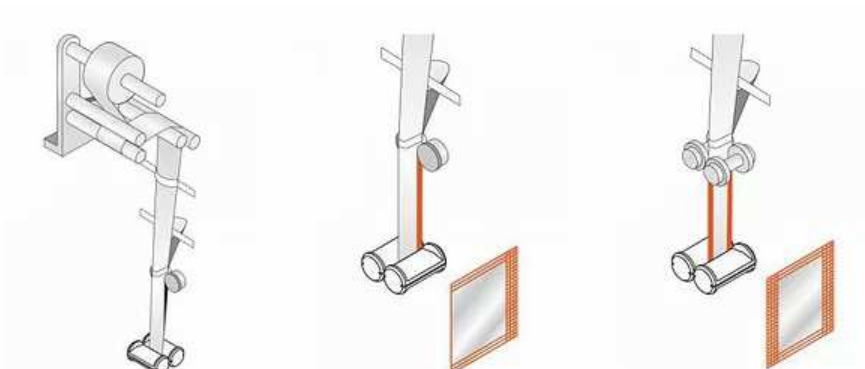

## Specification

Model	HD-180D
Feeding Station	1
Pouch Format	Flat
Packing Style	3-side seal/4-side seal
Pouch Material	Any Laminated Heat Sealable, ex.PET/OPP, PET/OPP
Max. Film Diameter	Max. 500 mm
Pouch Size	60*70mm ~ 90*180mm
Pouch Capacity	90 ml
Operating Speed	140ppm
Power Supply	380V 3 Phase 50Hz
Weight	Approx. 1600KG
Machine Size	4700*970*1535 mm

## Optional Device

- hanging hole
- easy tear