

# Pellets Extruder & Spheronizer



## Pellets Extruder & Spheronizer

### Pharmaceutical Pellet development on the Bench-top

*Work with batch sizes from 0.5kg to 5kg/1.0kg to 10kg*



ES-5

ES-10

The **ES** Series is the most complete bench-top spheronizer available as a standard configuration. It is a cost effective way of working with a wide range of batch sizes in a single apparatus. Work with small samples when product is scarce or costly. Work with larger samples when larger samples can be tested or when clinical trial quantities are required.

**Features:**

- Stainless steel 316L / 304 welded construction
- Siemens PLC & Touch Screen Control Panel
- Siemens Inverter
- Extruder granulating and spheronizer process in integrated in one unit
- Precise airflow adjustment
- The moist extruded granules be shaped into round pellets by spheronizer
- Extruder housing jacketed: The connections size is G1/8"
- Easy cleaning and maintenance
- Fully safety interlocked
- cGMP compliant



## ES-5 Dimensions:

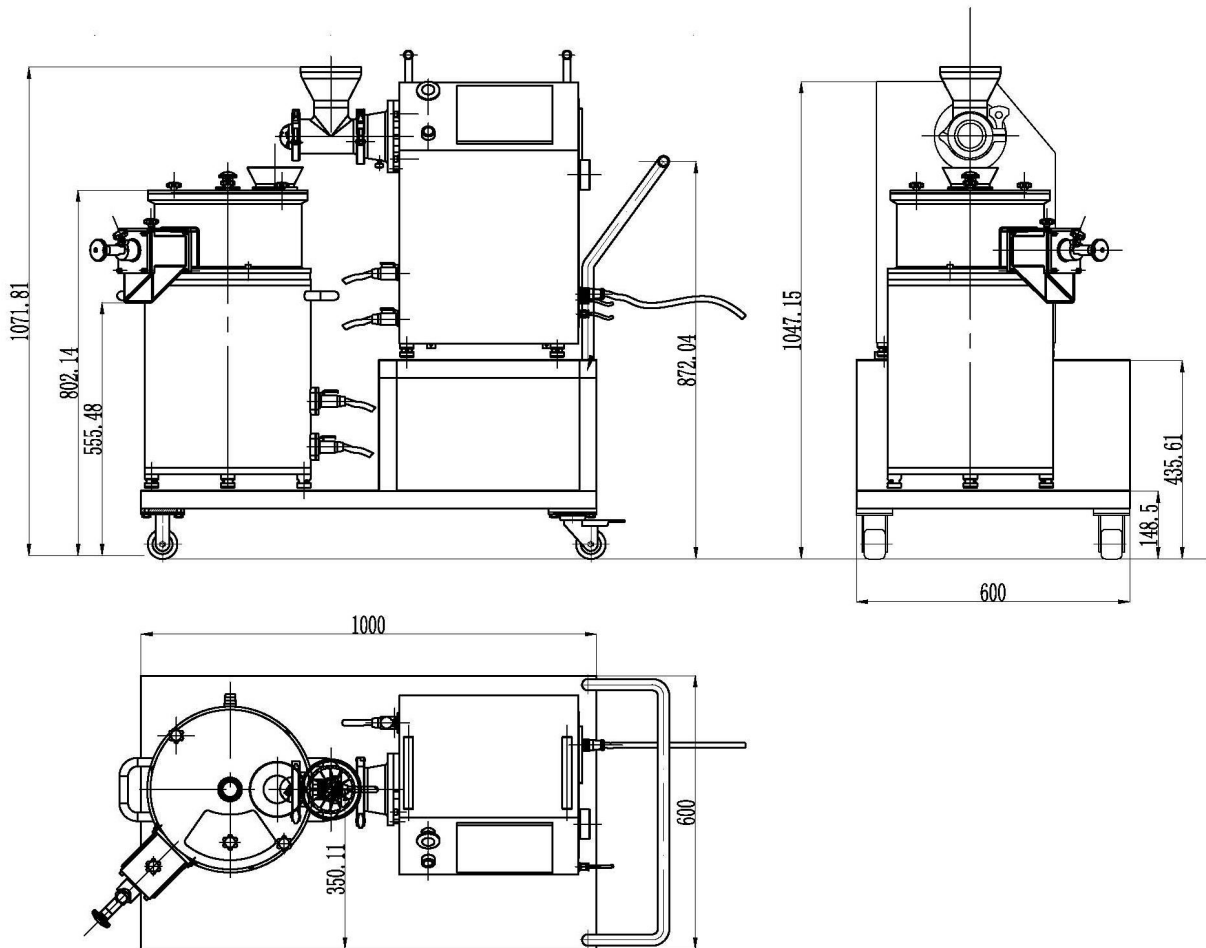

Technical Data	ES-5	ES-10
Capacity (kg/h)	0.5-5	1-10
Extruder Rotate speed (r/min)	10-100	10-100
Screw diameter (mm)	Φ50	Φ50
Turnplate rotate speed (r/min)	150-2000	150-2000
Turnplate dimension (mm)	Φ250	Φ315
Motor power (Kw)	2.57	2.6
Power supply (V/Hz)	220/380V,50/60Hz	220/380V,50/60Hz
Dimension (mm)	1490 x 600x 1100	1340 x 680 x 1230
Weight (Kg)	200	250

## Pellets Extruder & Spheronizer

### Pharmaceutical Pellet development on the Bench-top

*Work with batch sizes Up to 100kg*



ES-50

ES-100

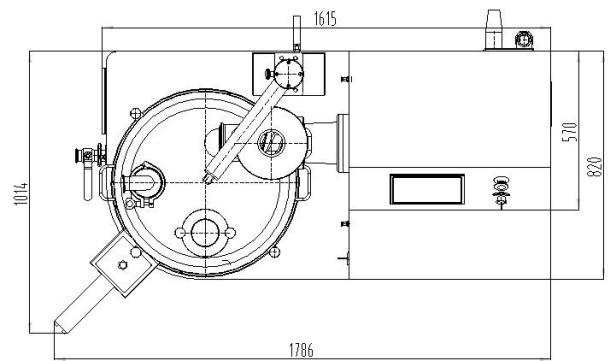
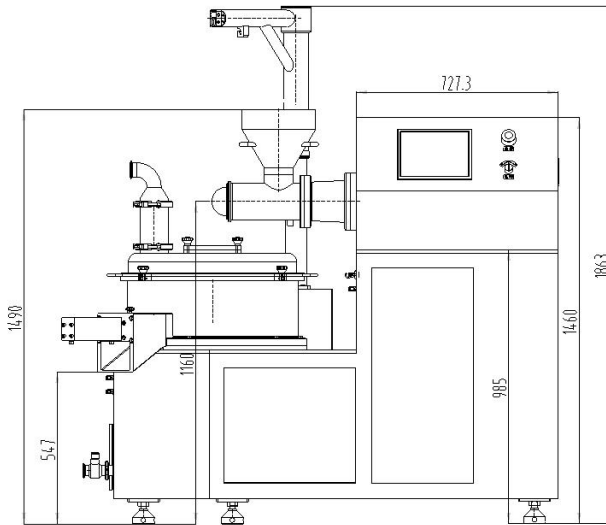

**ES-50/100 Dimensions:**

Technical Data	ES-50	ES-100
Capacity (kg/h)	0.5-50	1-100
Extruder Rotate speed (r/min)	8-80	8-80
Screw diameter (mm)	Φ100	Φ100
Trunplate rotate speed (r/min)	100-960	50-450
Turnplate dimension (mm)	Φ600	Φ1000
Motor power (Kw)	7.7	9.7
Power supply (V/Hz)	220/380V,50/60Hz	220/380V,50/60Hz
Dimension (mm)	1700 x 1000x 1950	1700 x 1000 x1950
Weight (Kg)	950	1200

SaintyCo also offer:

Encapsulation Solutions

Tablet Compression Solutions

Coating Systems

Cartoning Systems

Blister Packing Solutions

