



High Speed Horizontal Flow Wrapper Machine AAM-350H/450H/600H



Description:

Application

- Compact construction for reducing space required.
- Bag length indication ensures fast and accurate length adjustment.
- Specially designed feeding system is available for packaging soft and sticky products.
- Equipped with precision photocell sensor for film tracing control.

Optional Accessories

- Gusset device.
- Date coder.
- Adjustable bag former.
- Stainless steel machine frame.

Packaging Flow Chart:

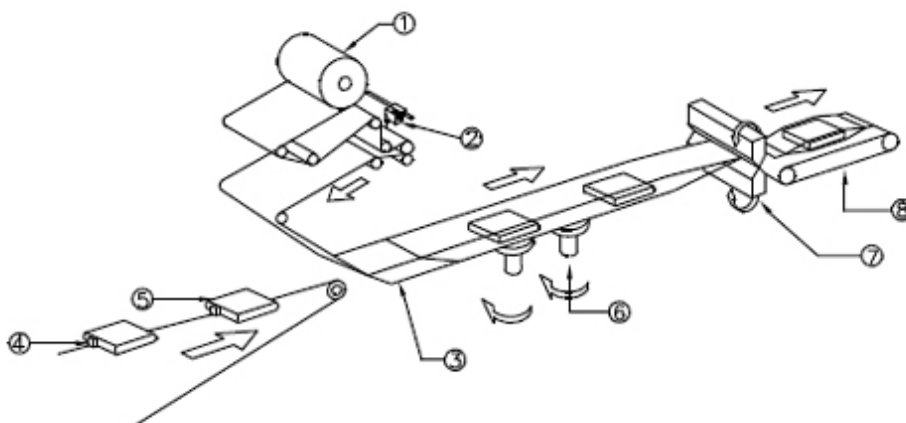

Specification:

Model	AAM-350H	AAM-450H	AAM-600H
Operating speed	20-150 pack/min	20-150 pack/min	20-150 pack/min
Bag length	8-32cm	8-32cm	10-40cm
Max. film width (max.roll dia.)	35cm(30cm)	45cm(30cm)	60cm(30cm)
Product width (max.)	2-12cm	2 - 12 cm (5 - 15 cm)	8 - 23 cm (11 - 27 cm)
Product height	Max. 5 cm	Max. 6.5 cm (12 cm)	Max. 6.5 cm (12 cm)
Main drive motor	1HP		
Heater	800 W for center sealer, 1200 W for end sealer		