

Horizontal Form Fill Seal Machine HD-270

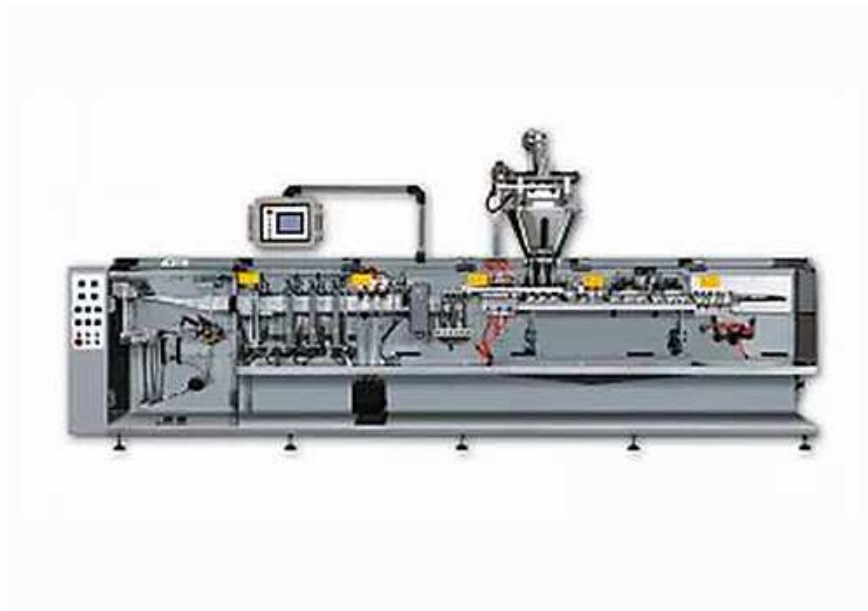

Features

- High-speed automatic splicer.
- Electronic cam servo package tractor.
- High reliable PLC control.
- With touch screen to display machine state, operation instruction, the state of breakdown.
- Keyence photoelectric color detector.
- Trio Motion Controllers.
- Camozz pneumatic control components.
- SMC Cylinder.
- Electronic cam servo device for small vehicles.
- Automatic control for material position.
- With safety switch and guard design.
- Connected parts with product made by stainless steel.
- Various of feeding system. (Servo Spiral, Measuring cup, Plunger pump, Gravity Feeder, Hibar Pump, Combination Weigher)

Bag Range

- L50~90*W60~140mm

Seal Type

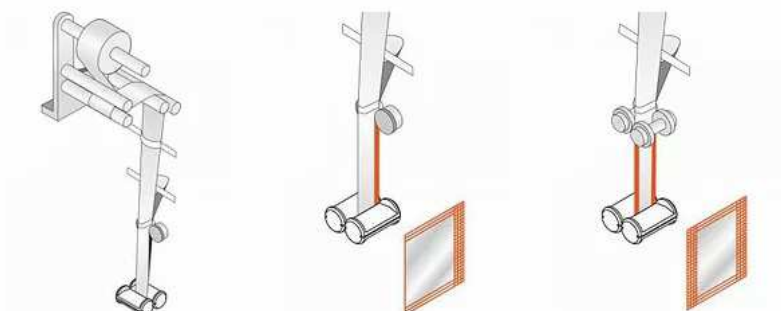

Specification

Model	HD-270T
Feeding Station	1
Pouch Format	Flat
Packing Style	3-side seal/4-side seal
Pouch Material	Any Laminated Heat Sealable, ex.PET/OPP, PET/OPP
Max. Film Diameter	Max.500 mm
Pouch Size	50*70mm~90*180 mm
Operating Speed	210ppm
Power Supply	380V 3 Phase 50Hz
Weight	Approx. 2300 KG
Machine Size	5650*970*1360 mm

Optional Device

- easy tear