

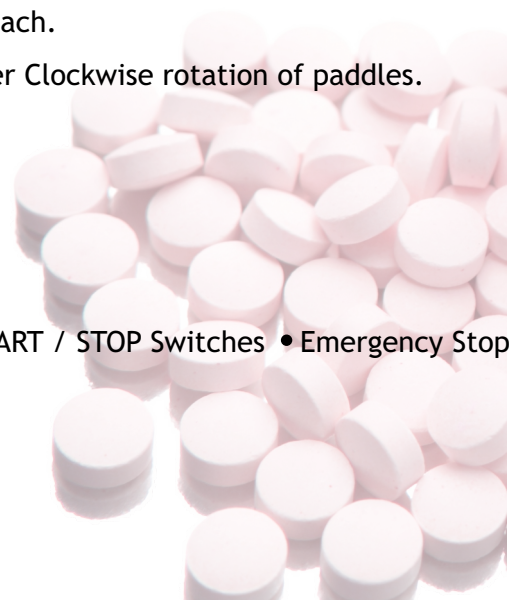

Salient Features

- Ideally suited for R & D plants, Pilot scale production, Pharmacy colleges, High value low volume products, Non Pharma applications.
- Fully cGMP compliant Tablet Press in terms of Design, Metallurgy, Easy Accessibility etc.
- Tool-less hopper fitment with tri-clover joint.
- Turret with Electroless Nickel Plating for excellent corrosion resistance & can be provided with 'D', 'B' or combination 'D', 'B' & 'BB' Tooling.
- Direct drive to the Turret - No intermediate gearing hence no power or traction loss.
- Large capacity motor ensures no jerks/slippages even when compressing large tablets.

- Equal sized Pre & Main Compression rollers of 60 kN (6 Ton) capacity each.
- Double Paddle Force Feeder with 'Peek Plate' with Clockwise & Counter Clockwise rotation of paddles.
- Pull down cam for reduced dust generation during upper punch entry.
- Segmented upper cam for easy cleaning & maintenance.
- Main & Feeder Motor control through AC Variable Frequency Drive.
- The integrated control panel includes :
 - Touch Screen HMI • Mode Selector Switch for SETUP / OFF / RUN • START / STOP Switches • Emergency Stop
- Compression & Ejection Force Measurement with Load Cell.
- "TOOL SAFE" overload system (Optional).



5.4" Touch Type HMI (Optional)



Tool Safe Overload System



Tablet Parameter Control

TECHNICAL SPECIFICATIONS

Model	EP - 200			
Tablet Press Type	Single Rotary			
Number of Stations	8	10	5 + 5	4 + 4 + 4
Tooling	EU-D	EU-B	EU-D + EU-B	EU-D + EU-B + EU BB
Tablet Output (Tab/hr) (Max.)*	14,400	18,000	9,000	7,200
Turret Speed	10 - 30 RPM			
Tablet Diameter (Max.)	22 mm	16 mm	22 / 16 mm	11 / 16 / 13 mm
Filling Cam Depth	12 / 16 mm	8 / 12 / 17 mm	12 / 16 mm	12 / 16 mm
Tablet Thickness (Max.)	8 mm			
Upper Punch Insert	2 - 4 mm			
Main Pressure (Max.)	Rated 60 kN (6 Ton) - Continues 50 kN (5 Ton)			
Pre Pressure (Max.)	Rated 60 kN (6 Ton) - Continues 50 kN (5 Ton)			
Feeder	Force Feeder (standard) Gravity Feeder - (optional)			
Machine Footprint - Main Machine	690 x 900 mm			
Machine Height (without Hopper)	1260 mm			
Machine Height (with Hopper)	1360 mm			
Net Weight	730 kg			
Gross Weight	840 kg			

* Machine output mentioned are rated outputs and can vary depending on the product characteristics, Tablet dimensions / shape / size, depth of fill, ambient conditions, operators skill and machine maintenance.

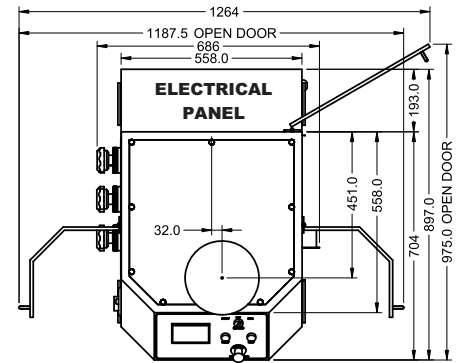

TOP VIEW



Force Feeder with Bottom Drive

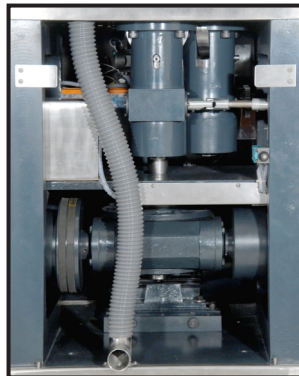

Direct Drive to Turret

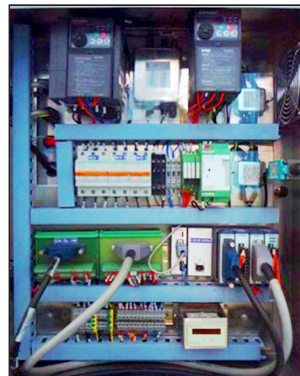

Electrical Panel

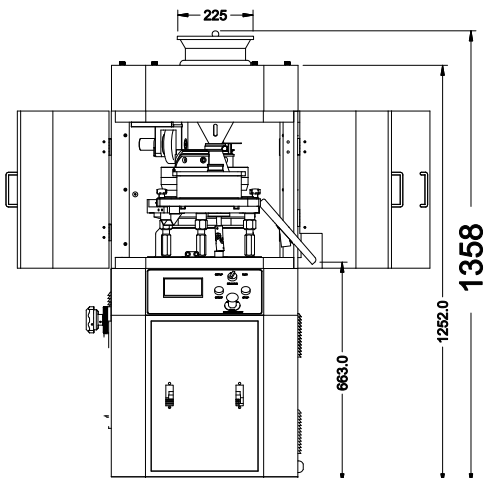

SIDE VIEW



SERVICE SUPPORT

- ▶ Ahmedabad
- ▶ Chennai
- ▶ Hyderabad
- ▶ Bengaluru
- ▶ Delhi
- ▶ Indore
- ▶ Chandigarh
- ▶ Goa
- ▶ Sikkim



Parle Elizabeth Tools Pvt. Ltd.

329/P, Behind J.K Weigh Bridge, Opp. Harsha Engineering,
Changodar, Ahmedabad, - 382213 Tel: +91 7600017570
info@parle-elizabeth.com www.parle-elizabeth.com

BRANCH OFFICE

- ▶ Ahmedabad
- ▶ Delhi
- ▶ Pinjore
- ▶ Bengaluru
- ▶ Goa
- ▶ Hyderabad
- ▶ Chennai

The specifications & images are subject to change without prior notice due to continuous innovation policy.
© 2015, Parle Elizabeth Tools Pvt. Ltd. All rights reserved, Rev. 3.0, March, 2015

Eliza-Press