

F

luid-Bed Dryer

FG Series



Fluid-Bed Dryer

FG Series Fluid-Bed Dryer is one of the main process equipments in the solid dosage production procedure in pharmaceutical industry, and is also widely used in chemical, foodstuff industries, etc. This equipment is set with mixing and drying functions.



Features:

This equipment is successfully designed on the basis of a wide research, absorption and digestion of foreign advanced models. It has a reasonable structure with stable performances and easy operation; the whole machine has no dead angle or protruded screws. PLC is designed to ensure a fully automatic control. All the operations are automatically finished according to the customer's set parameters; moreover, process parameters can be printed and records of original data are fully true and reliable. FG Series Fluid-Bed Granulators comply entirely with GMP requirements for medicine production.

Principle:

This equipment is composed of main machine (Processor), air handling unit (AHU), heating and control systems. When operating, charge the materials into the FBD Bowl, set the procedure and parameters according to process requirements and then, start the processor. The inlet air is filtered by the air handling unit (AHU) and heated by the heating system, and then the processed air enters the processor to blow up materials into fluidization condition. Materials are apace dried and moisture rapidly vaporized. When the operation has been finished according to the set procedure and parameters; move out the FBD Bowl to lock with NTF Series FBG Bowl Post hoist for lifting and discharging the produced granules. During the whole process, powder dust and cross pollution are effectively controlled.

Dimensions:

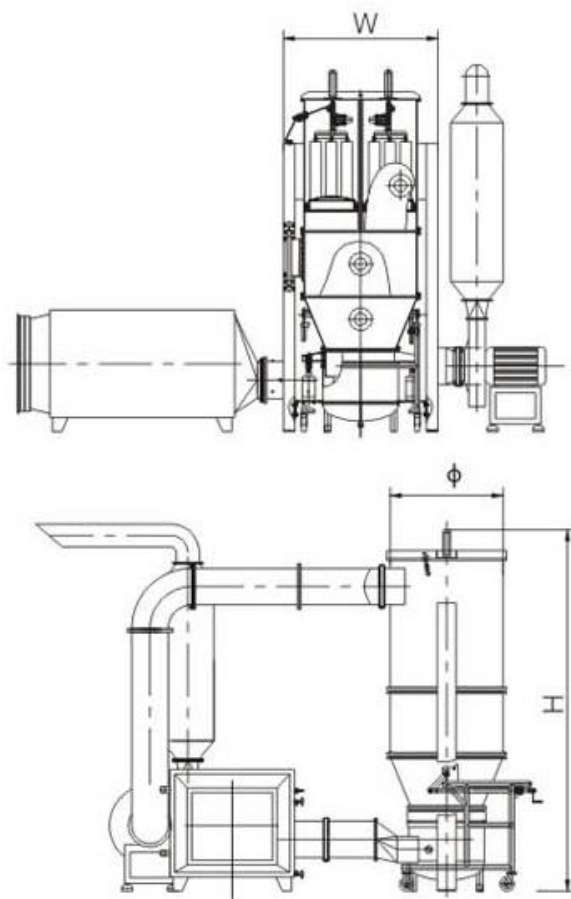

Technical Data			FG5	FG15	FG30	FG60	FG120	FG200	FG300	FG500
Materials Bowl Volume	L		22	45	100	250	420	670	1060	1500
Production capacity	Kg/batch		5	15	30	60	120	200	300	500
Steam	Pressure	Mpa	0.4~0.6							
	Consumption	Kg/h	18	33	166	166	213	405	686	400
Compressed air	Pressure	Mpa	0.45~0.6							
	Consumption	Kg/h	0.3	0.6	1	1	1	1	1.8	1.5
Fan power	Kw		5.5	7.5	11	18.5	18.5	30	45	55
Outline dimensions	W	mm	820	870	1200	1460	1650	1890	2090	2300
	H	mm	2250	2350	3130	3865	3900	4520	4850	5450
	Ø	mm	500	550	800	1000	1200	1400	1600	1800

SaintyCo also offer:

Encapsulation Solutions

Tablet Compression Solutions

Coating Systems

Cartoning Systems

Blister Packing Solutions

