

## *KENO-L116 Sticker Orientation Labeling Machine*

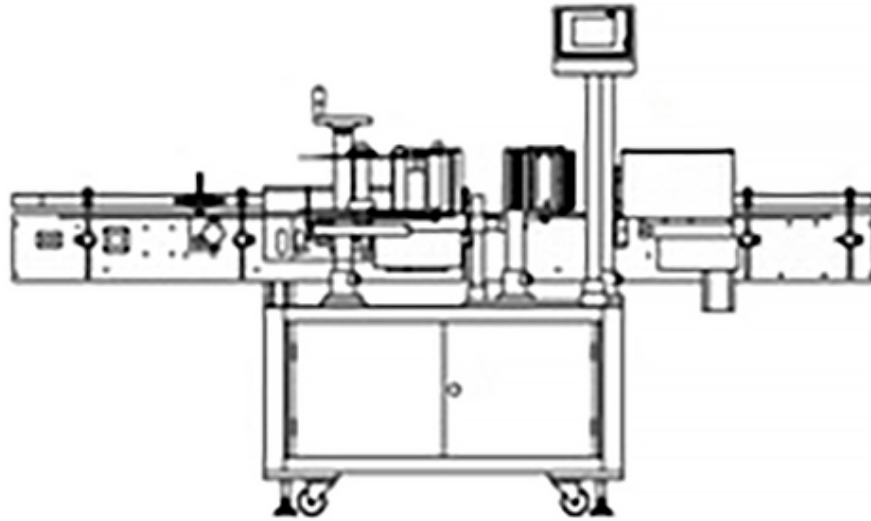

This machine is widely used for labeling of round containers in food, medicine, fine chemical and etc. This machine adopts servo motor for control.

The human-machine touch screen is convenient and easy to operate; the rich failure display function can realize EXACTITUDE labeling.

### **Technical Parameters**

<b>Model</b>	<b>KENO-L116</b>
Drive	Step Motor Driven
Direction	Right / Left
Labeling Speed	0-100 pcs/min
Bottle Diameter	20-80mm
Bottle Height	25-350mm
Label Size	Width: 12-90mm Length: 15-200mm
Precision	±0.3mm
Label Roll	Max: 300mm
Label Core	Stander: 75mm
Machine Size	2000*1300*1500mm
Weight	220Kg
Power	AV 110V/220V 50/60Hz 1200W
Coding Device	DT-380