



HORIZONTAL LINEAR CARTONER

• *Adaptable* • *Compact* • *Ergonomic*



NHC-40

MAIN FEATURES

- Up to 30 cartons per minute
- Reliable servo controlled motion
- Delicate carton handling via nest
- Industry Leading Compact Footprint
- Ergonomic design
- Stainless Steel Frame Standard



NHC-40 HORIZONTAL LINEAR CARTONER

• Adaptable • Compact • Ergonomic

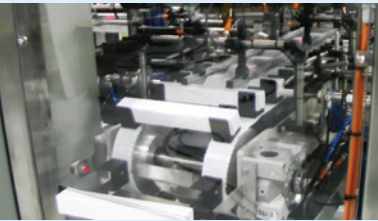
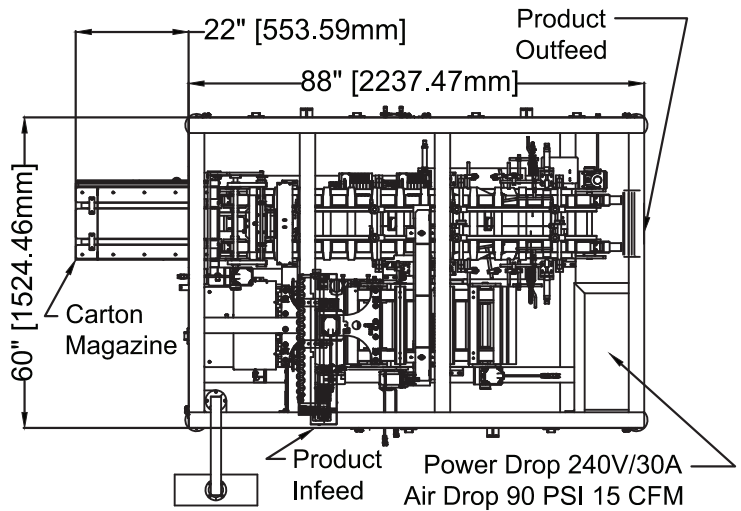
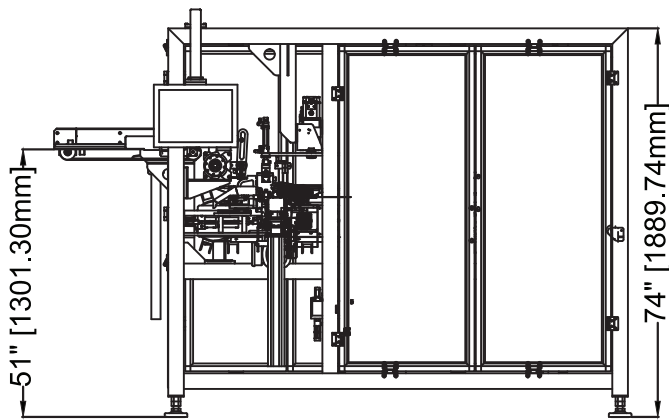

SPECIFICATIONS:

DRIVE:	Servo driven intermittent motion
SPEED:	Up to 40 cartons per minute
PRODUCT SIZE RANGE:	Per Project Specification
CARTON SIZE RANGE:	Length: min - 3" (76mm) max - 12" (305mm) Width: min - 1" (25mm) max - 5" (127mm) Height: min - 1" (25mm) max - 5" (127mm)
CARTON FEED:	Servo driven, positively erecting cartons into buckets, delicate handling
MODE:	- Linear intermittent motion - Multiple operating stations allowing, direct or field installation of options including: <ul style="list-style-type: none"> • Leaflet insertion • Barcode reader • Missing product detection • Printer • Open flap detection • Automatic reject - High speed in-feed systems are designed to meet specific product loading - Hot melt system or fold and tuck (airplane or reverse)
CONTROLS:	Bosch Rexroth, Omron, Allen Bradley with touch screen HMI
MAGAZINE CAPACITY:	Up to 700 cartons
FRAME:	Complete stainless steel construction
GUARDING:	Full length polycarbonate with extruded aluminum frames
FINISH:	All parts in contact with product are stainless steel, anodized aluminum or delrin.
INSTALLATION REQUIREMENTS:	Power: 240 VAC with 3 phase @ 20 amps. Air: 90 PSI, 10 cfm
VALIDATION (optional):	Open flaps inspection, barcode scanner, product present verification, and reject station



400 Steeprock Drive, Toronto
Ontario, Canada, M3J 2X1
Tel: (416) 663 7071
www.nuspark.com

Distributed by