

WRAPPER 4000T

SPECIAL FEATURES

- High speed
- Low and easy maintenance
- Link ability
- High productivity

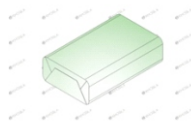

Line Drawing of the Pack

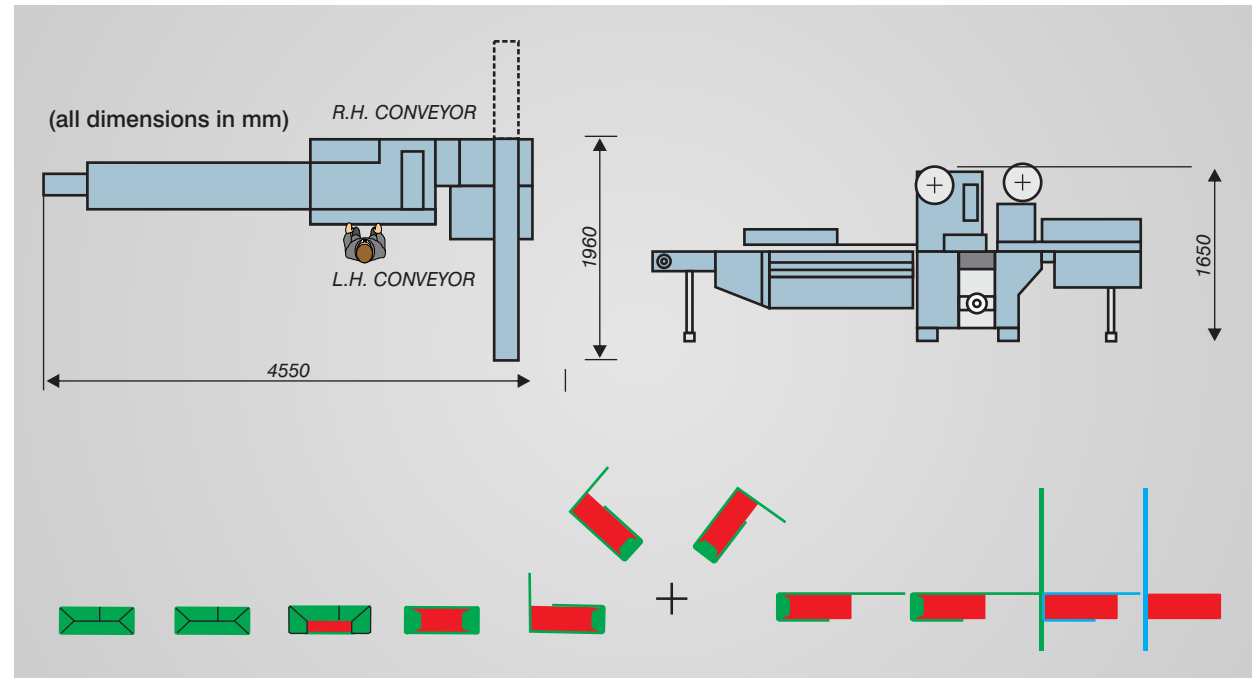

SPECIFICATIONS

Pack Size (L x W x H)	Max. (120 x 50 x 30)mm Min. (55 x 30 x 10)mm
Total Power Consumption	3.3 KW
Electricals	220 V A.C, 1 PH, 50 HZ
Speed	Upto160 PPM (machine speed and accuracy is dependent of quality of packing material, soap size and its quality, uniform inflow of the product)
WRAPPING MATERIAL	
For Stiffener –CARD PAPER / POLY LAMINATE	PAPER / POLY / HOT MEAL LAMINATION
Maximum Reel Width (Packaging Material Dimension)	150 MM
Maximum Reel Diameter(Packaging Material Dimension)	600 MM
Core Dia of Reel	76 MM
Bare Machine Size (L X W X H)	4440 x 1800 x 1760
Packed Machine Size (L X W X H)	144" x 42" x 85"
Bare Machine Weight	2040 kg
Packed Machine weight	2760 kg
Packed Conveyor Size (L X W X H)	75" x 20" x 25"
Bare Conveyor Weight	220 kg
Packed Conveyor Weight	320 kg



KHOSLA MACHINES PVT. LTD.
B-17, Industrial Area, Phase-2,
Mohali 160 051, Punjab, INDIA.

TELEFAX : 91 +172+ 2225587
Website : www.khoslamachines.com
E-mail : info@khoslamachines.com

Technical specifications may vary because of continuous development



KHOSLA
listen innovate deliver

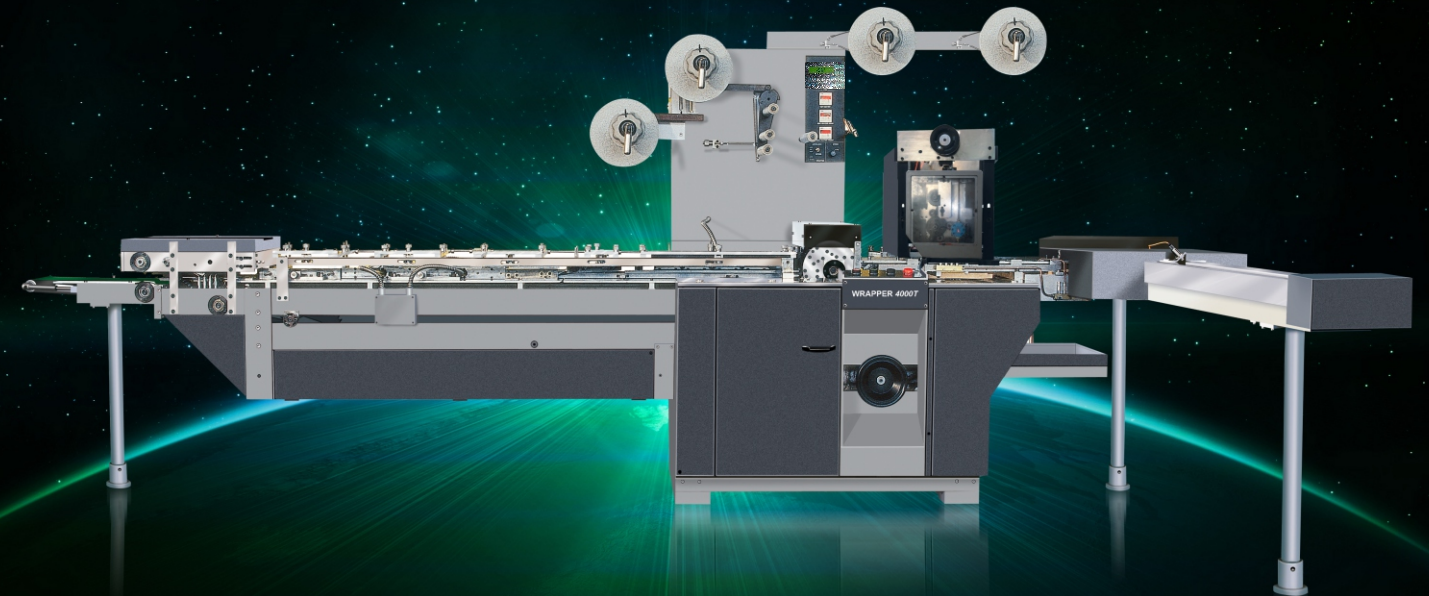

WRAPPER 4000T

TOILET SOAP WRAPPING MACHINE



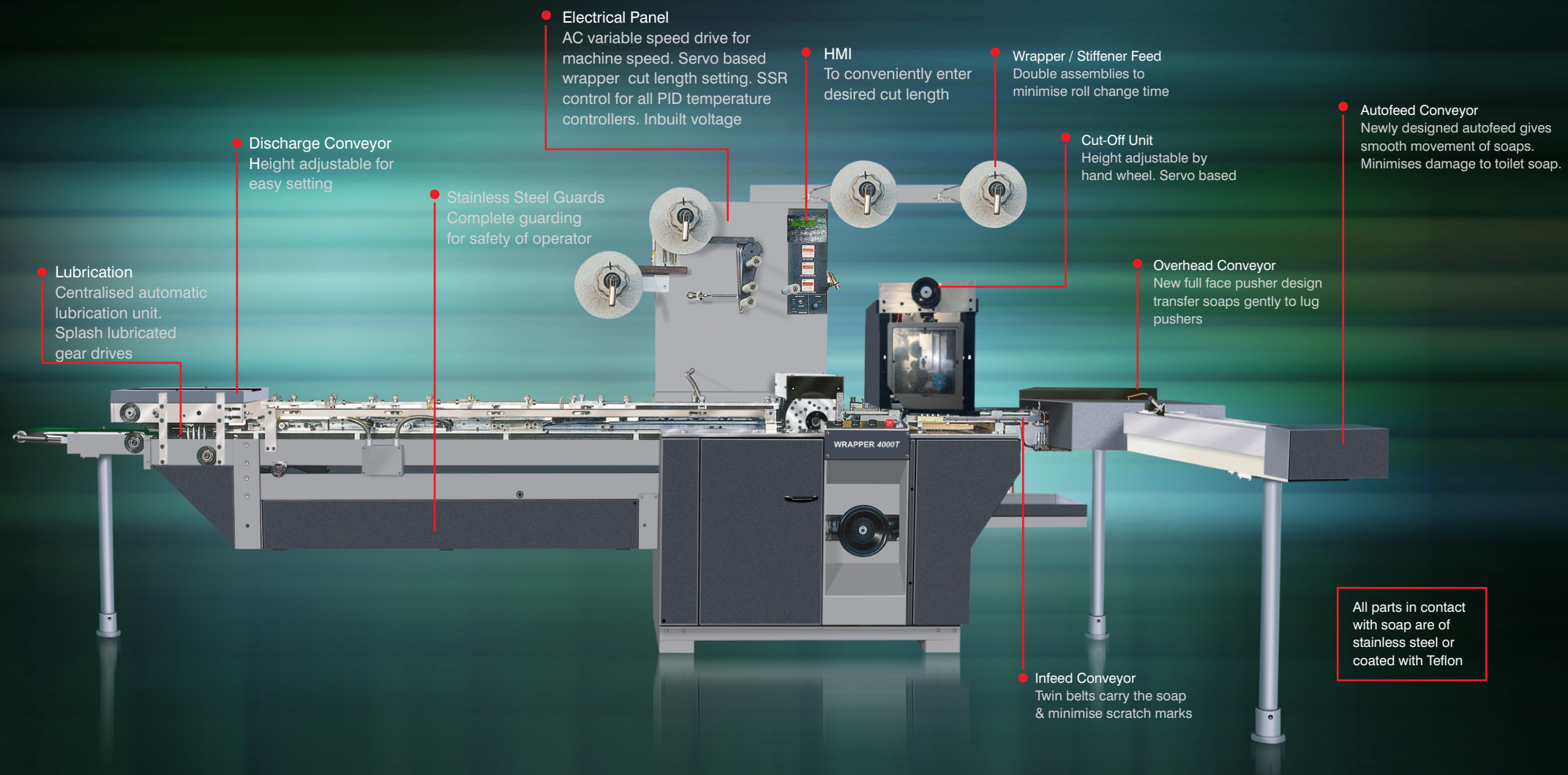

STANDARD FEATURES

- Heavy cast iron structure for vibration absorption and durability.
- No – product - No-wrap interlock.
- Cut off height setting by means of handwheel.
- Discharge height setting by means of handwheel.
- Automatic Print Registration Unit by means of imported sensor.
- PID temperature controls from Honeywell or equivalent make.
- VFD speed control.
- The machine speed upto 160 ppm (machine speed and accuracy is dependent of quality of packing material, soap size and its quality, uniform inflow of the product)
- Heavy distortion free cast structure

OPTIONAL FEATURES

- Collation Unit for wrapped soaps for easy collection on discharge conveyor.
- Stainless steel guarding.
- Double Spool Holders for stiffener and wrapper.
- Change parts
- Centralised lubrication unit.
- Tool Kit.
- Emergency Spares kit.
- Customised infeed conveyor.
- Web break interlock.
- Mirror image orientation to allow single operator to run two machines.



OUR OTHER MACHINES FOR SOAP WRAPPING

- Wrapper 8000T : 6 Servo based, high speed toilet soap wrapping machine
- Wrapper 4000 : Detergent bar wrapping machine
- ABM3100 : Automatic banding machine for soap
- Finseal 2040 : Pouch pack machine for soap in 2x2 or 3x3 collation

