

Wrap around Labelling Machine **WCL 20.1**



■ Application

Wrap around labelling of round shaped containers

■ Features

- Designed for 20m/minute label dispensing speed
- Label positional accuracy of $\pm 0.5\text{mm}$
- Very easy to operate
- Ergonomically designed to allow easy job change
- Low changeover time
- Rigid frame construction
- All components are surface treated
- Stepper motor driven labelling head
- All adjustments are provided with scale
- Touch screen operator interface adjustable for height
- Recipes facility
- Exhaustive on screen diagnostics
- Fully enclosed control cabinet



*Graphics shown on the containers are the property & trademark of the respective brands

Wrap around Labelling Machine WCL 20.1

Technical Data

- Label Dispensing Speed : 20 meters / minute ^
- Accuracy : Label positional accuracy of $\pm 0.5\text{mm}$
- Power : 1.3kW, three phase, 415 VAC, 50Hz
- Max. Part Height : 300mm
- Max. Part Diameter : 120mm
- Min. Part Height : 30mm
- Min. Label : 30mm (height)*
- Max. Label : 200mm (height)
- Media Roll Size : 300mm (diameter) 3" core
- Machine Weight : 600KG
- Operating Air# : 60LPM (0.06m³/min) at 6 bar

^ Speed in BPM is dependent on part diameter and label length.

*If all your label heights are less than 100mm, our WCL 20.1.100 model is suitable.

#For use with optional two roller attachment.

Optionals

- Two roller attachment
- Language options for different countries
- Label break sensor
- Remote Diagnostics
- Label roll diameter sensor to alarm roll changeover
- Accept/reject station
- Password and user log facility
- PackML

Layout

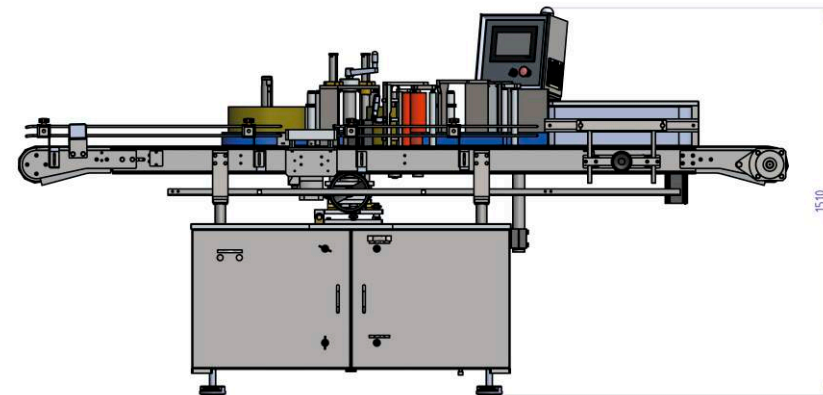
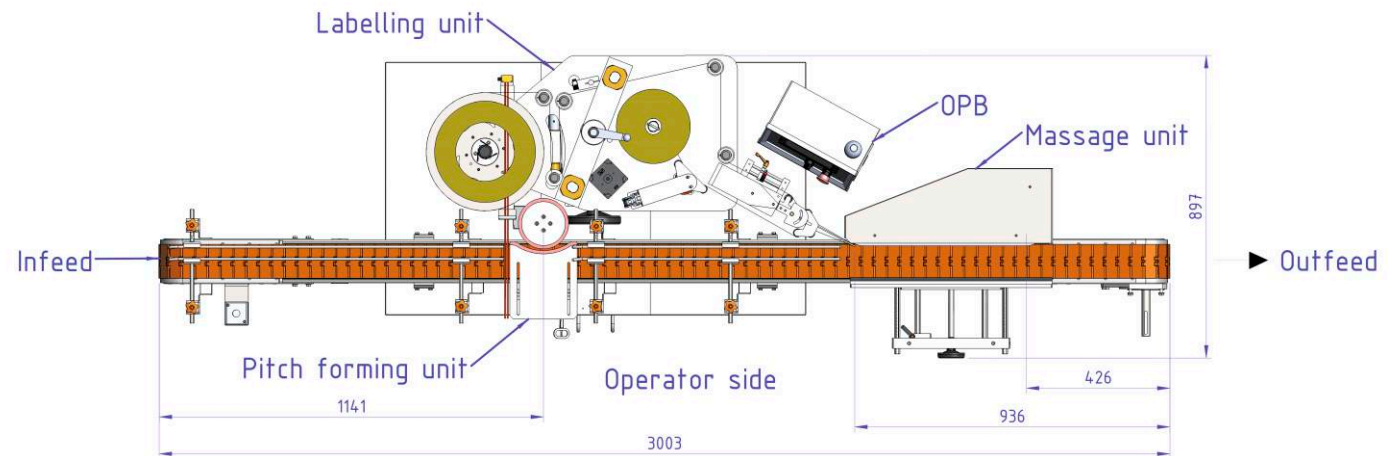

Technoshell
Automations Pvt. Ltd.

G - 49, M.I.D.C., Ambad, Nashik - 422010. INDIA

Ph.: +91 253 6647 300.

Email: info@technoshell.com URL: www.technoshell.com

Scan To Play Video

