

GQW105

Semi-Auto Wrapper (Mechanical) 半自動無預拉膠膜機(機械張力調整)

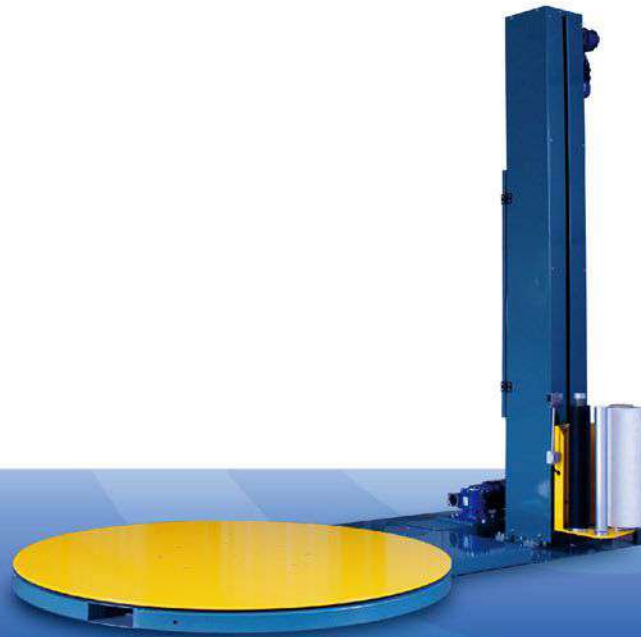

Key Features

- PLC with the inverter controls motor.
- The turntable is driven by the belt, which makes it turning in no noise, stable and smooth.
- The film carriage has the patented anti-drop device to ensure safety.
- The speed of the turntable and the film carriage can be adjusted by the inverter.
- The turntable has soft start / stop to ensure safety.
- It can be switched to manual or auto mode.
- Controlled by control panel.
- The sensor detects the packing height automatically.
- Mechanically adjust the tension. Manually rotate to adjust the tightness of the stretch film.
- Manually fix the film to the pallet first and then turn on the wrapper.
- Separate 1~9 top and bottom wrap count is adjustable.

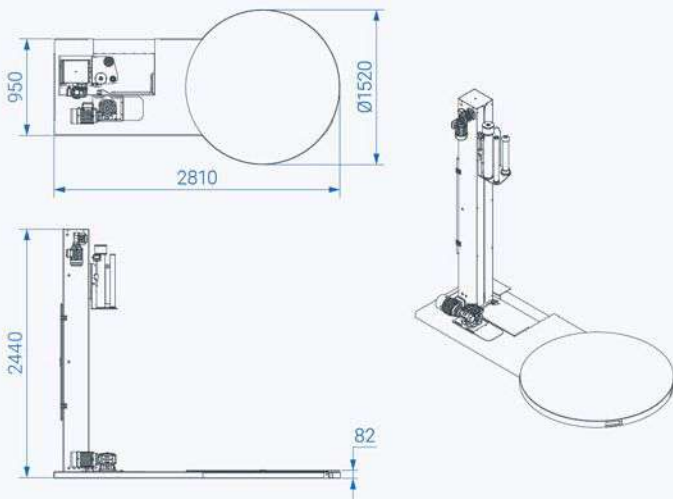

特性

- PLC程式控制，搭配變頻器控制馬達。
- 皮帶式轉盤傳動，轉動無噪音、平穩順暢。
- 專利防墜裝置，保障使用安全。
- 轉盤及膠膜座速度，可無段變頻調整。
- 轉盤具和緩啟動/停止功能，確保產品安全。
- 可切換手動/自動操作模式。
- 操作面板控制。
- 電眼自動偵測包裝物高度。
- 機械式張力調整，以手動旋轉方式調整膠膜鬆緊度。
- 需手動將膠膜固定到棧板上再啟動。
- 上下裹包圈數：1~9圈可調整。

Machine Size	Turntable Dia.	Turntable Height	Optional	Applicable Film
機械尺寸	轉盤直徑	轉盤高度	選配	適用膠膜
L2820 × W1520 × H2440 mm Spec. subject to change without prior notice. 機台尺寸以實際製作為準	1500 mm Optional: Customized size is available. 可訂製加大	82 mm	Ramp 斜拖板	PE 20~30μ
Max. Load Weight	Max. Wrap Height	Film Carriage Speed	Turntable Speed	Voltage
乘載重量	裹包高度	昇降速度	轉盤速度	電壓
1500 kg Optional: 2000 kg 可選購：2000 kg	2000 mm	3 M/min Adjustable. 可調	12 RPM Adjustable. 可調	1Φ, 220V Depend on customer's request. 可依客戶需求指定