

Sieve

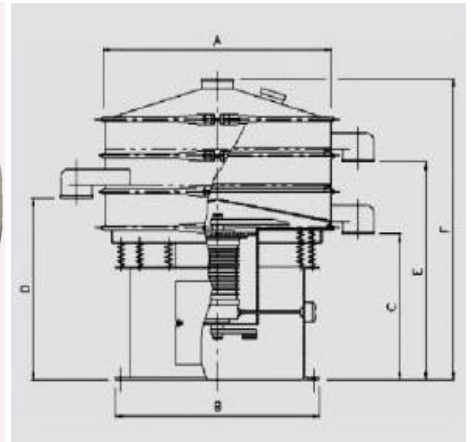

● Principle

- The purpose is to sift powder products according to sizes of granules.
- By means of vibration motor are sifted powder products and discharged it according to mesh size with specified dimension.

● Application

Pharmaceutical, Food & Chemical Industry

Specification

Model	Deck weight(kg)	A	B	C	D	E	F	HP
KGO-450-1	160	450	600	490	590	750		Veritcal
KGO-450-2	170	450	600	490	590	750	830	Veritcal
KGO-600-1	180	600	600	480	590	835	-	Ø0.85kW
KGO-600-2	200	600	600	480	590	835	970	Ø0.85kW
KGO-800-1	260	800	650	480	590	840	-	Ø0.85kW
KGO-800-2	300	800	650	480	590	840	990	Ø0.85kW
KGO-1000-1	440	1000	850	570	730	1010	-	Ø1.5kW
KGO-1000-2	500	1000	850	570	730	1010	1130	Ø1.5kW
KGO-1200-1	710	1200	950	570	730	1045	-	Ø1.5kW
KGO-1200-2	790	1200	950	570	730	1045	1130	Ø1.5kW
KGO-1500-1	780	1500	1120	590	740	1080	-	Ø2.2kW
KGO-1500-2	970	1500	1120	590	740	1080	1235	Ø2.2kW

※As specification of your order, change for manufacturing of capacity