



SERIES For Your Core Labeling Needs



**Distributors
Invited**

Minimize cost, downtime and training with CORE Series labelers from EPI. Industrial grade components are cleverly engineered into a compact, durable platform to provide years of service. The menu driven touch-screen minimizes training, provides intuitive control as well as audible/visual status indication. Automatic calibration and open label paths, makes label size changes fast and easy. Available for wipe-on, and Tamp/Blow applications. All CORE Series Labelers come with a 3-year limited warranty.

Why EPI?

For over 30 years EPI Labelers have been designed and engineered for reliability and ease of use. We take the time to understand each application and listen to our customers' needs. Let us show you how precise thinking and simple design can help you.

Reliable

EPI Labelers are built to stand up to the daily use and harsh environments that come with the territory. Enclosed direct drive technology along with corrosion resistant material allows our labelers to work in dusty, wet and cold packaging operations with a minimum amount of maintenance required. Your operators and mechanics will appreciate EPI Labelers ease of set up and use.

Versatile

Sure, EPI Labelers are easy to set up and operate, but the versatility that is engineered into all our equipment allows you to use our labelers in a variety of applications. Whether your job calls for a non contact vacuum/blow, tamp or two panel application we can configure our labelers to meet your needs.

Quick and Easy Setup

Our customers tell us that EPI Labelers give them the ease of use that they have not experienced with other labeler equipment. The cantilevered design which lends itself to easy threading, and the simple mechanical adjustments to change label size, make EPI Labelers a favorite of mechanics and operators everywhere.

Core Series Labeler -Tamp/Blow



CORE SERIES

Label Size: 1" x 1" to 4" x 6"

Label Supply: 12" OD on a 3" Core

Electrical: 2A @ 120 VAC 60HZ

Speed: Up to 1000 IPM

Pneumatic: 2 SCFM, 60 PSI

Configurations: Tamp
Blow
Tamp/Blow

Mounting: 1.5" tube clamp included

Cylinder Stroke: 6"

Product Sensor Included

If viewing this document electronically,
[click here](#) for additional information.

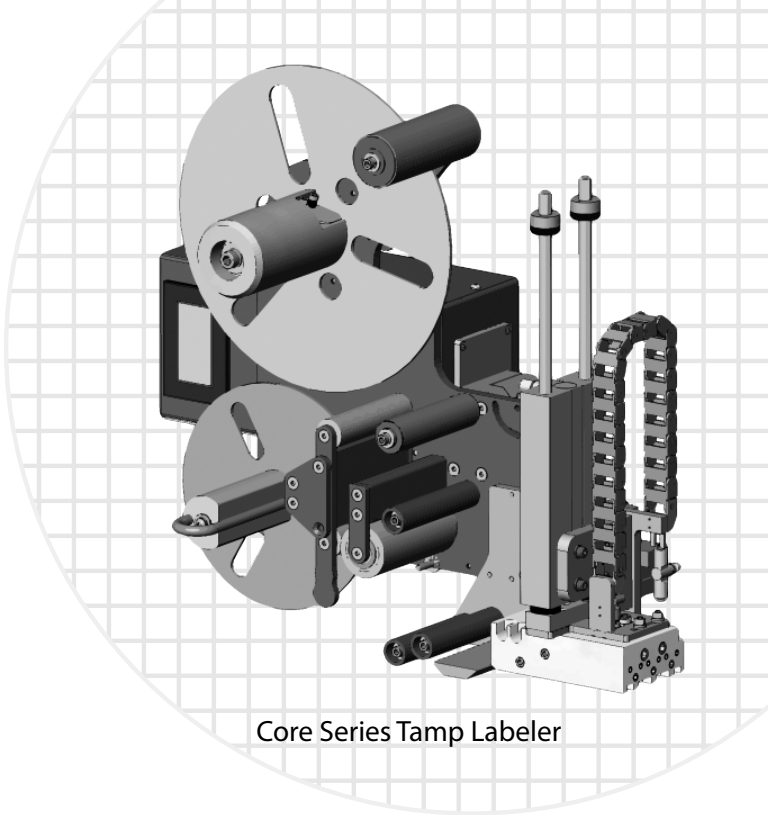

Core Series Tamp Labeler

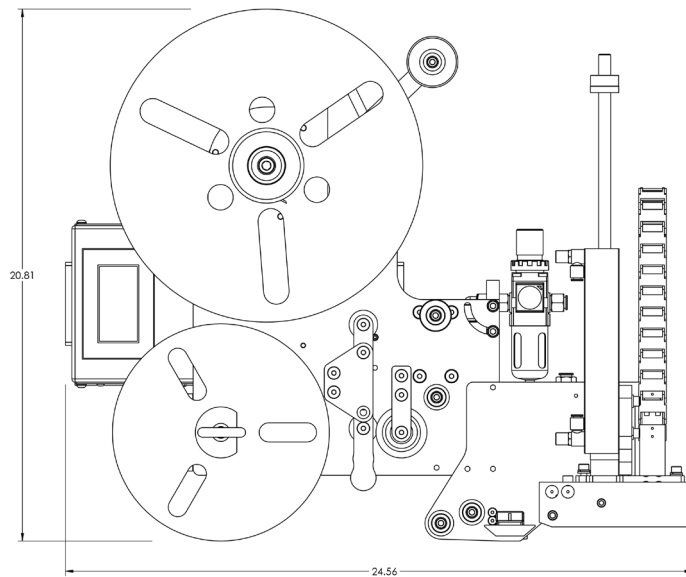

Specifications

Precise Thinking. Simple Design. Simple - Precise - Durable. These words have defined our labeling equipment since our inception in 1980. EPI Labelers are used in a wide variety of industries, from food packaged in flexible material to warehouse case labeling. Our equipment integrates with a wide variety of packaging equipment, is easy to operate, and will give you years of dependable service.

Customer Commitment: Our design and service teams know that the simpler the design the less likely you are to have costly downtime. We are proud to offer our customers PMMI certified training. If you should require after-sale service, our technicians are available for both onsite and phone service, and will stick with you to solve the problem. Our extensive inventory of parts allow us to ship most parts orders the same day to minimize your downtime.

EPI
LABELERS powered by Pro Mach 

www.epilabelers.com
sales@epilabelers.com

717.235.8345
800.755.8344
1145 East Wellspring Rd
New Freedom, PA 17349

