

# WRAPPER 4000

## SPECIAL FEATURES

- High speed
- Low and easy maintenance
- Link ability
- High productivity

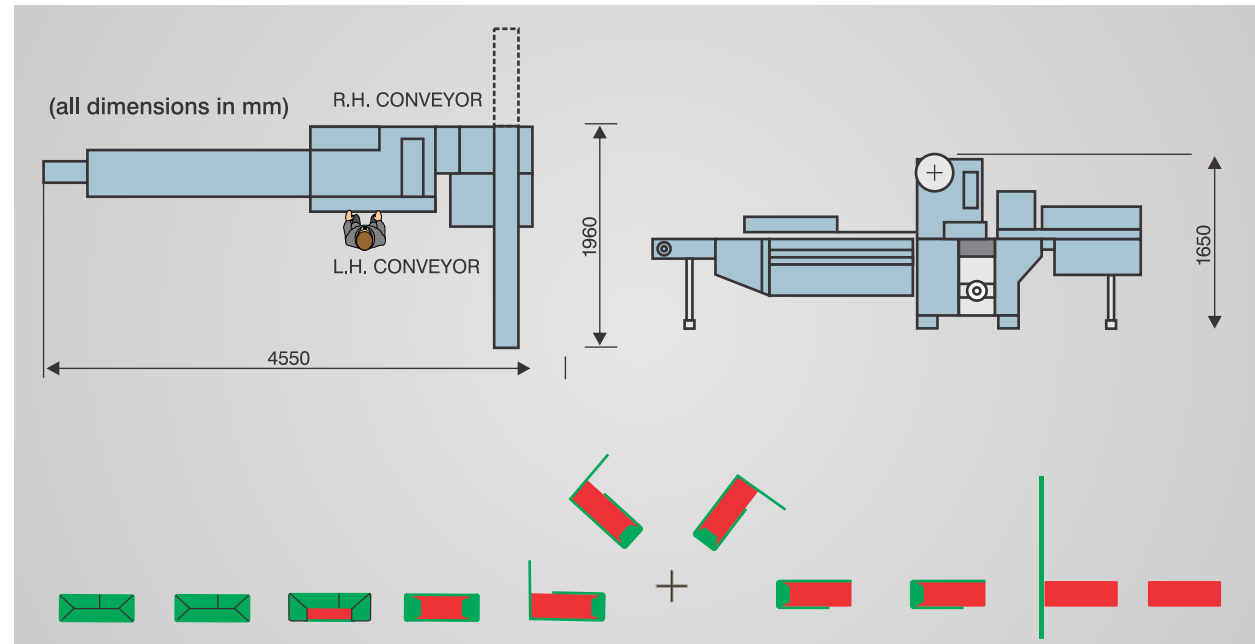

## SPECIFICATIONS

Pack Size (L x W x H)	Max (175 x 65 x 40) mm, Min (65 x 35 x 13) mm
Line Drawing of the pack	
Electricals	220 V, 1 Phase, 50 HZ
Speed	160 PPM (machine speed and accuracy is dependent of quality of packing material, soap size and its quality, uniform inflow of the product)
WRAPPING MATERIAL	Paper/ Poly/ Hot melt Lamination
Maximum Reel Width (Packaging Material Dimension)	205 MM
Maximum Reel Diameter(Packaging Material Dimension)	600 MM
Core Dia of Reel	76 MM
Bare Machine Size (L X W X H)	4440 x 1800 x 1760
Packed Machine Size (L X W X H)	144" x 42" x 85"
Bare Machine Weight	2020 kg
Packed Machine weight	2720 kg
Packed Conveyor Size (L X W X H )	75 x 20 x 25
Bare Conveyor Weight	220 kg
Packed Conveyor Weight	320 kg



**KHOSLA MACHINES PVT. LTD.**  
B-17, Industrial Area, Phase-2,  
Mohali 160 051, Punjab, INDIA.

TELEFAX : 91 +172+2225587  
Website : [www.khoslamachines.com](http://www.khoslamachines.com)  
E-mail : [info@khoslamachines.com](mailto:info@khoslamachines.com)

buzzinc.com

Technical specifications may vary because of continuous development



**KHOSLA**  
listen innovate deliver



## WRAPPER 4000

DETERGENT BAR / LAUNDRY SOAP  
WRAPPING MACHINE



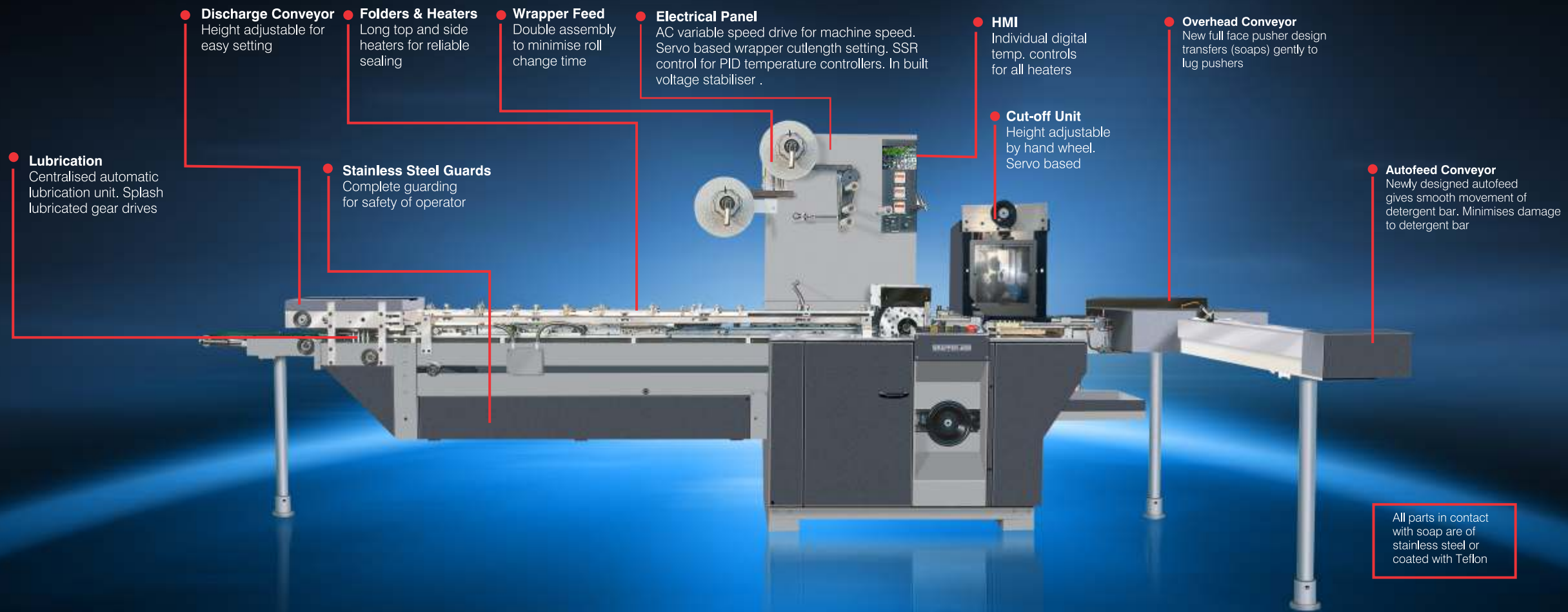

## STANDARD FEATURES

- Heavy cast iron structure for vibration absorption and durability.
- No – product - No-wrap interlock.
- Web break interlock.
- Cut off height setting by means of handwheel.
- Discharge height setting by means of handwheel.
- Automatic Print Registration Unit by means of imported sensor.
- PID temperature controls from Honeywell or equivalent make.
- VFD speed control.
- The machine speed is upto 160 PPM (machine speed and accuracy is dependent of quality of packing material, soap size and its quality, uniform inflow of the product)
- Heavy distortion free cast structure

## OPTIONAL FEATURES

- Collation Unit for wrapped soaps for easy collection on discharge conveyor.
- Stainless steel guarding.
- Change parts
- Centralised lubrication unit.
- Tool Kit.
- Emergency Spares kit.
- Customised infeed conveyor.
- Web break interlock.
- Mirror image orientation to allow single operator to run two machines.



## OUR OTHER MACHINES FOR SOAP WRAPPING

LOGIPAC 2010, WRAPPER 8000T, WRAPPER 4000T, ABM3100, ABM2100, FINSEAL 2040

