



— Pharma Process & Packaging

www.saintyco.com

Stripack-350

ADVANCED STRIP PACKING MACHINE

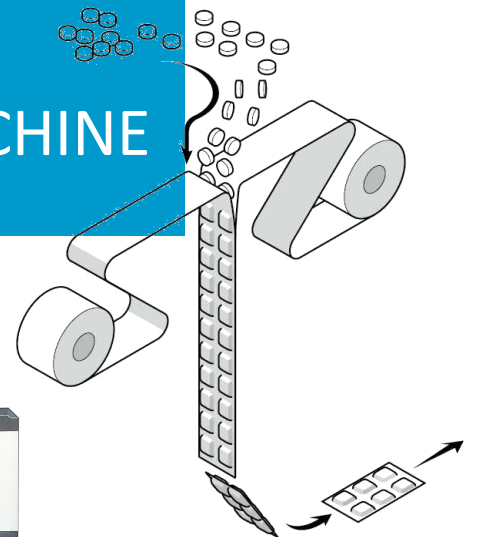

ADVANCED STRIP PACKING MACHINE

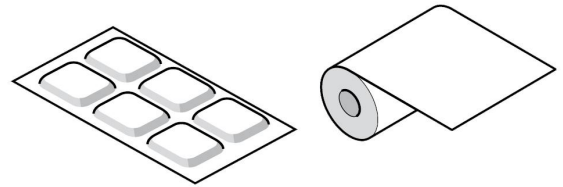

The four side sealed foil pack containing pharmaceutical solids is widely known as strip pack.

For several applications it is a growing alternative to other kinds of packaging.

The range of machines produce high quality 4 side sealed packs.

The packaging materials are fed from 2 reels to the sealing station where the products are fed precisely timed in between the 2 layers of foil before being sealed together by temperature and pressure.

Quality inspection systems for the products after sealing are available as options.

After sealing the foil web is perforated and cut into the required pack sizes.

The finished and qualified packs can then be grouped and transferred to the relevant end packing system(s).

Stripack-350

Features:

Feeding system

- Product supply hopper
- Dust and breakage elimination system, incl. dedusting facilities
- Sorting vibrator feeding channels for high feeding capacity with extremely quiet operation
- Vertical product indexing unit, quickly exchangeable.

Sealing quality

- Sensing of seal temperature by integrated sensors
- Multiple heaters per sealing tool
- Quick heat-distribution components
- Handling of all seal parameters (pressure/gap/temperature/speed) in panel
- Film unwinding with constant tension
- Various seal patterns to adapt to the quality of the packaging material

cGMP aspects

- Surface finish according to pharmaceutical regulations
- Consequent balcony design with separation of drive and function modules
- Easy access to the product feeding for cleaning and format exchange
- General execution as per cGMP regulations

Availability

- Quick format change-over due to minimized number of format parts
- Individually pluggable draw-off modules
- Integrated touchscreen operator panel
- Foil reel shafts with quick release locks for fast change-overs
- Low space requirement due to compact design

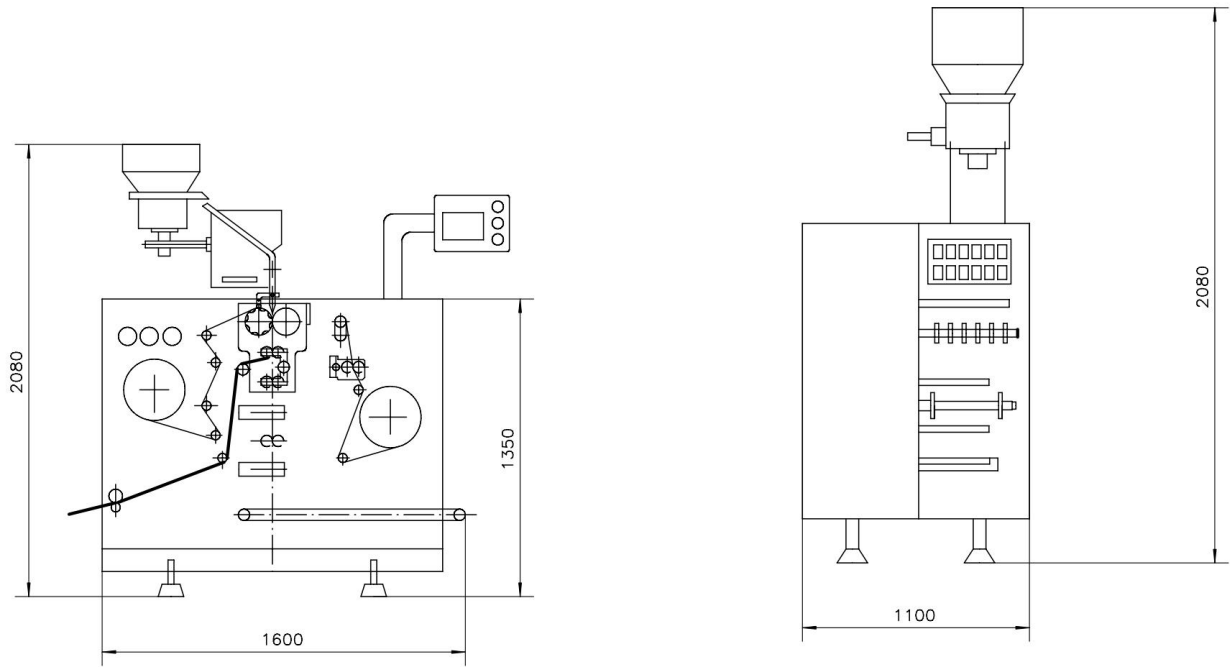

Technical Data		Stripack-350
Width of foil roll		350mm
Dia of foil roll		300mm
Speed of strip		3-3.5m/min
Punch frequency		20-60cuts/min
Compressed Air		0.5Mpa≥0.2mP ^{3P} /min
Power Supply	heating	2×2.1kw=4.2kw
	motor	0.75kw
Net. Weight		1200kg
Dimension L×W×H		1600×1200×1900mm

SaintyCo also offer:

Softgel Manufacturing Line

Capsule Printer

Capsule Counting Line

Cartoning Systems

Blister Packing Solutions

