

# Cartoning Machine *for Tube*

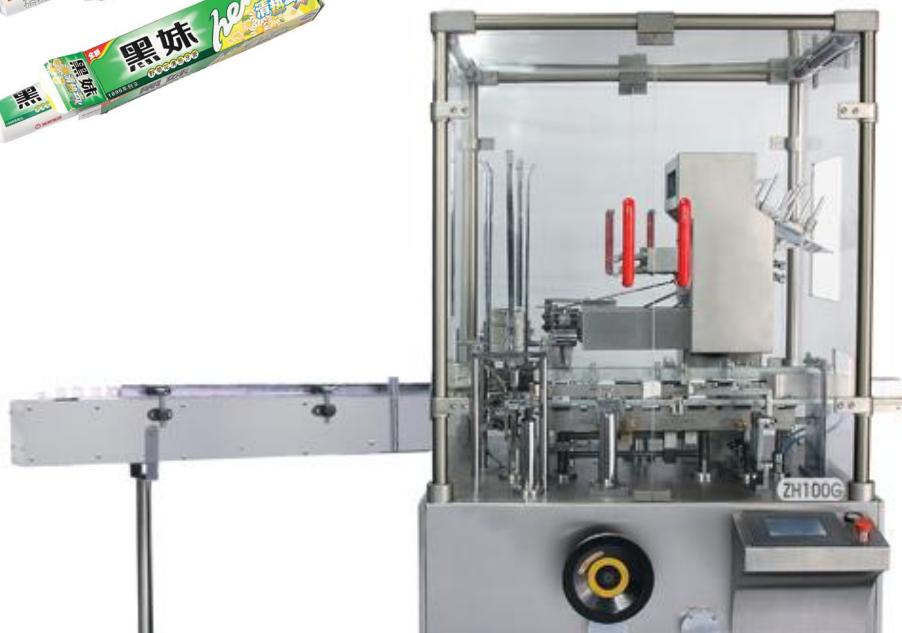

## Cartoning Machine *for Tube*

The **ZH-100G** cartoning machine is suitable for cardboard case packaging of ointment medicine, glass bottle and soft package (packed condoms). It consists of direction folding (1-4folds) and feeding equipment, cardboard case forming and feeding, batch number printing, sealing of case tongues at both ends etc. The whole encasing process is finished automatically. It can be added hot-glue machine.



**Features:**

- High speed: up to 7,200 cartons/h
- International famous brand of electrical component such as PLC touch screen, frequency inverters, etc.
- Adopt human-machine operation system.
- Automatically stop when machine is overload.
- Automatically reject lacking of package product and leaflet.
- Automatically display trouble, Alarm and count finished products.
- Stable performance, operation is easy.

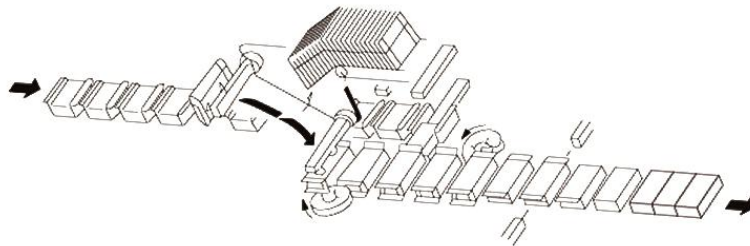

**Dimensions:**

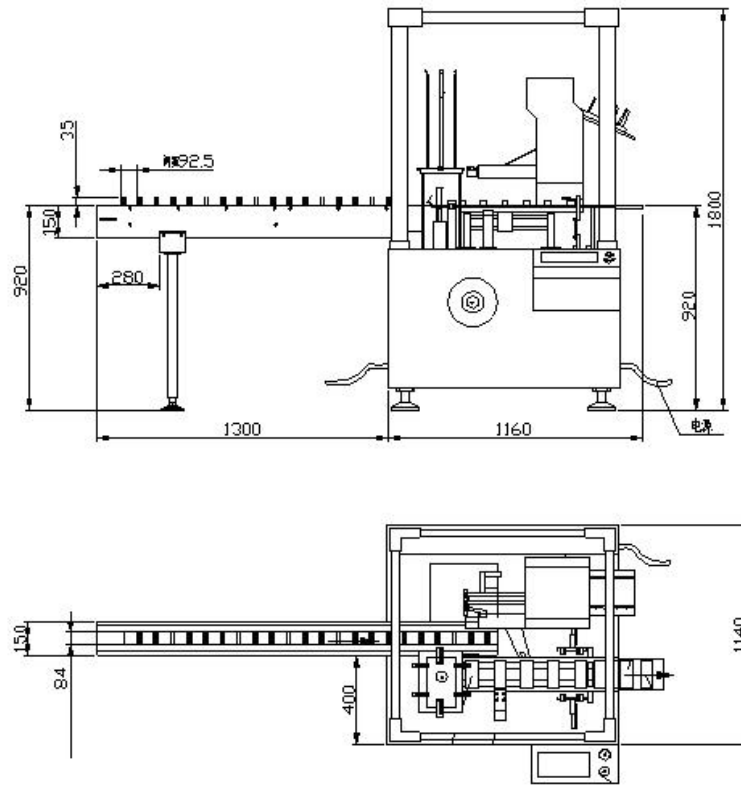

Main technical parameters		ZH-100G
Encasing speed		30-120cartons/min
Carton	Quality requirement	250-350g/m <sup>2</sup> Base on carton size
	Dimension range(L*W*H)	(65-155) *(30-85) *(15-50)mm
Leaflet	Quality requirement	60-70g/ m <sup>2</sup>
	Unfolded leaflet specification	(80-250) *(90-170)mm
	Fold range	1-4 fold
Compressed air	Working pressure	≥0.6mpa
	Air consumption	120-160L/min
Power supply		220V 50HZ
Motor power		0.75Kw
Machine dimension(L*W*H)		2300*1140*1800mm
Machine weight		1200kg

SaintyCo also offer:

Encapsulation Solutions

Tablet Compression Solutions

Coating Systems

Cartoning Systems

Blister Packing Solutions

