



EPI-9210

Pressure Sensitive Labeling System for Top & Bottom Labeling

The EPI-9210 Labeling System from ID Technology, is designed to label the top and bottom of clamshell and tub style containers and cartons neatly and accurately. The system features simple vertical and horizontal adjustments to allow for quick and reliable label placement.

EPI-9210 works on nearly all types of packaging, and is ideal for cosmetic, personal healthcare and retail food including, baked goods, produce and confectioneries. It is made with corrosion resistant materials, is designed to withstand harsh conditions, and will integrate to your specific packaging process.

The solid construction promises durability and reliability that will make it a staple in your packaging process for many years.



Key Features

- Consolidated electrical controls for a plug and play system.
- Easy to navigate full color touchscreen for both top and bottom labelers.
- Standard encoder speed matching capabilities.
- High torque stepper motors used for precision accuracy.
- Record time changeover capabilities with tool-less adjustments.

EPI-9210 Pressure Sensitive Labeling System

The 9000 Series is a range of robust, competitively priced labeling equipment designed to handle a wide range of applications. 9000 Series products are built in the USA, in our production facilities in Oakland, NJ, New Freedom, PA and Fort Worth, TX. With nationwide on-site support and six label printing plants, ID Technology can help streamline and enhance your labeling operations.

Features

Label Size: 1" x 2" to 5" x 12"
Smaller/Larger size optional

Label Supply: 12" OD on a 3" core
Larger size optional

Product Size: 4" - 12" Wide - Standard
2" - 24" Long - Standard
Larger sizes optional

Electrical: 6A @ 120VAC, 60 HZ

Speed: Variable up to 100 FPM

Conveyor: Stainless Steel, Aluminum
UHMW, Powder Coated Steel

Options:

- 16" Label Supply
- Increased Label Width
- Low Label Supply Warning with Auto Shut-Off Feature and Beacon Light
- Different Supply Voltage
- Clear Label Sensor Package
- Washdown Package
- Additional Conveyor Width
- Additional Conveyor Length
- Adjustable Feet
- Higher Speed

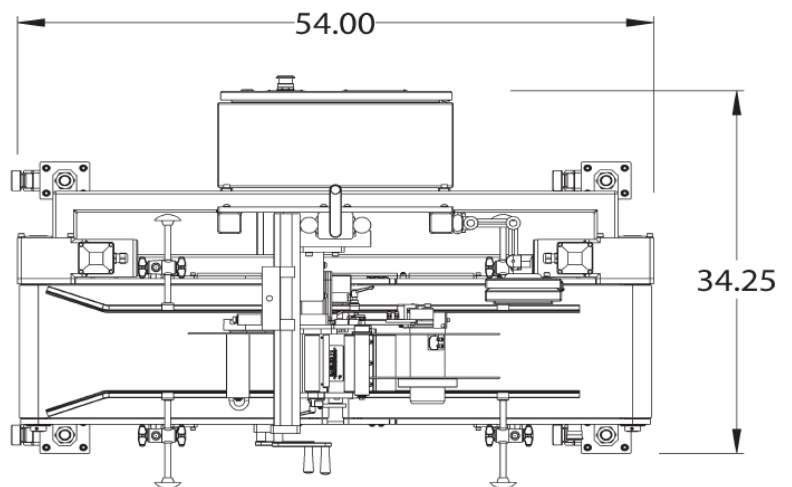
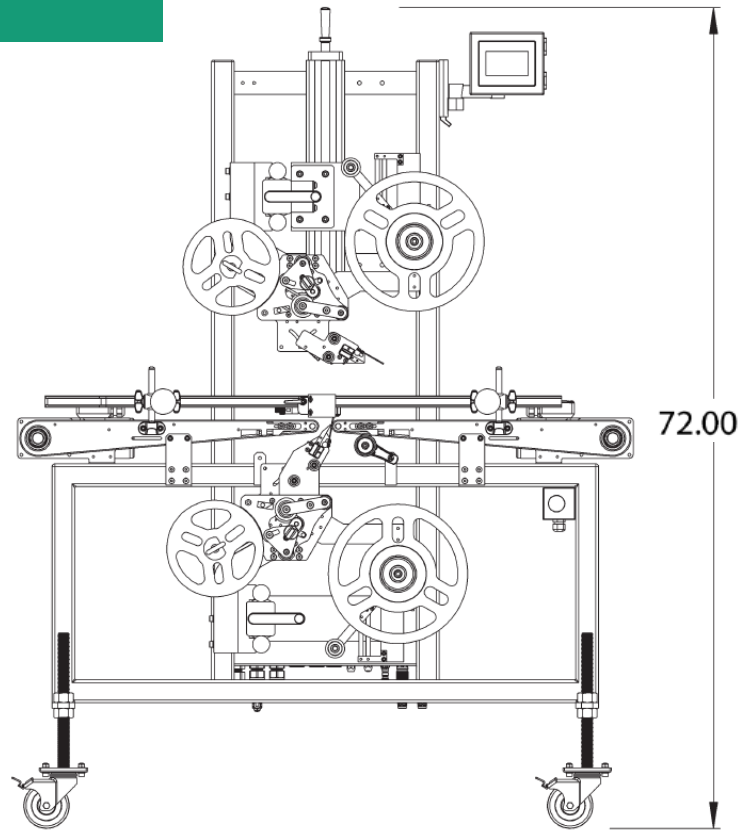

*Complimentary
Lifetime Equipment Warranty*