

Lifting Conic Mill-Moveable

ZLT Series



Lifting Conic Mill-Moveable

ZLT series Lifting Conic Mill is mainly widely used in pharmaceutical, chemical, foodstuff industries, etc. for mill and homogenization of granules, and de-agglomeration of agglomerates in order to obtain acceptable uniform granules according to the process requirements.



Principle:

Move the Lifting conic mill under NTF Series Pharma Lifter, for FBG/FBD Bowl; and align it with the butterfly valve of the cone adapter. Then, start operating; granules are discharged into the cone mill where they are going to be extruded, cut and grinded by the mill blades which force the granules to pass through the conical screen and get a uniform size. And finally, granules are discharged into bins.

Features:

The chassis is set with four casters supporting a great mobility. The height of the mill cum sifter can be raised or lowered according to specific height requirements, therefore satisfying customer's production process requirements. Consequently, powder dust or cross pollution are effectively avoided. ZLT Series Lifting Mill cum Sifter complies entirely with GMP requirements for medicine production.

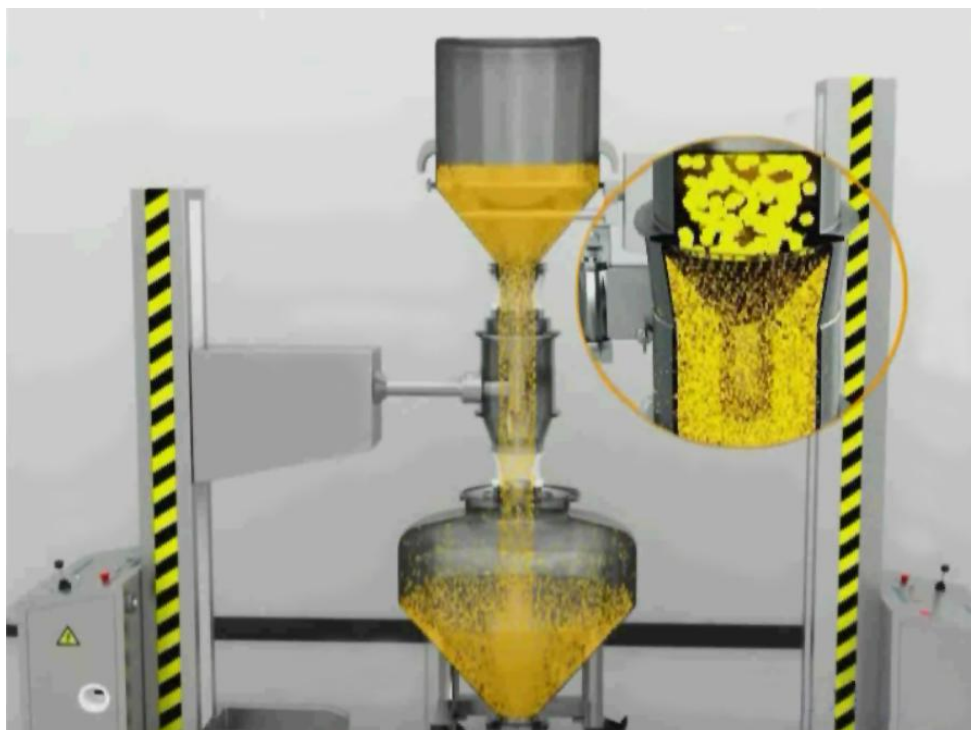

Dimensions:

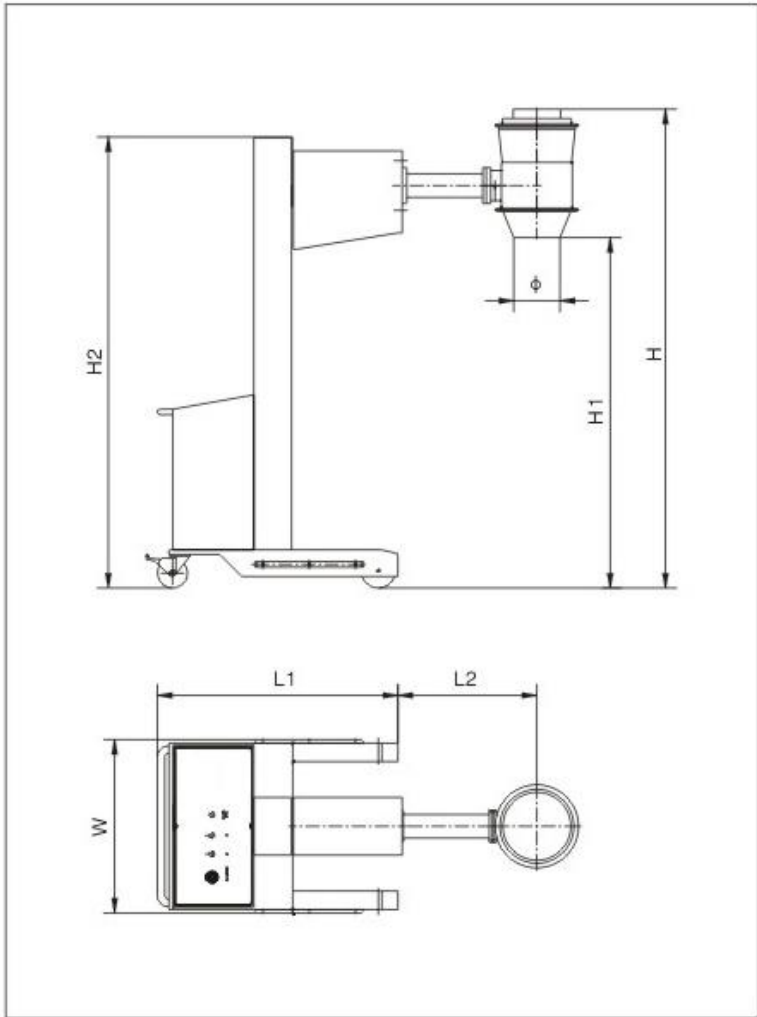

Technical Data													
Model	L1	L2	W	H			H1			H2	Ø	Power Kw	Max mill production capacity kg/h
				Low Pos	Mid.Pos	High Pos	Low Pos	Mid.Pos	High Pos	Column			
ZLT200	950	600	650	2030	2530	3030	1500	2000	2500	1950	200	1.1	200
ZLT450	950	600	650	2070	2570	3070	1500	2000	2500	1950	200	4.0	450
ZLT700	950	600	650	2080	2580	3080	1500	2000	2500	1950	200	5.5	700
ZLT1000	950	600	650	2100	2600	3100	1500	2000	2500	1950	200	5.5	1000

SaintyCo also offer:

Encapsulation Solutions

Tablet Compression Solutions

Coating Systems

Cartoning Systems

Blister Packing Solutions

