



# EPI-9220

## Pressure Sensitive Labeling System for Clamshell Type Containers

This C-Wrap System from ID Technology, incorporates a small split conveyor with an M-Series Labeling Head to adhere labels to the top, front, and bottom of a clamshell container. The conveyor presents the filled clamshell to the labeler, the label is applied to the package and a dual wipe mechanism firmly secures the label.

EPI-9220 applies labels accurately and gently on each container. This system is ideal to ensure the clamshells remain securely closed from the packaging line to distribution and onto the retail shelf.



### Key Features

- Consolidated electrical controls for a plug and play system.
- Easy to navigate full color touchscreen for HMI.
- Standard encoder speed matching capabilities.
- High torque stepper motors used for precision accuracy.
- Fast changeover capabilities with tool-less adjustments

## EPI-9220 Pressure Sensitive Labeling System

The 9000 Series is a range of robust, competitively priced labeling equipment designed to handle a wide range of applications. 9000 Series products are built in the USA, in our production facilities in Oakland, NJ, New Freedom, PA and Fort Worth, TX. With nationwide on-site support and six label printing plants, ID Technology can help streamline and enhance your labeling operations.

### Features

**Label Size:** 1"x2" to 5"x24"  
Smaller/Larger size optional

**Label Supply:** 12" OD on a 3" Core

**Product Size:** 4"-12" Wide - Standard  
2"-24" Long - Standard  
Larger sizes optional

**Electrical:** 3A @ 120VAC, 60HZ  
Different supply voltage optional

**Speed:** Variable up to 100 FPM

**Conveyor:** Stainless Steel, Aluminum,  
UHMW, Powder Coated Steel

**Options:**

- 16" Label Supply
- Increased Label Width
- Low Label Supply Warning with Auto Shut-Off Feature and Beacon Light
- Different Supply Voltage
- Clear Label Sensor Package
- Washdown Package
- Additional Conveyor Width
- Additional Conveyor Length
- Adjustable Feet
- Higher Speed

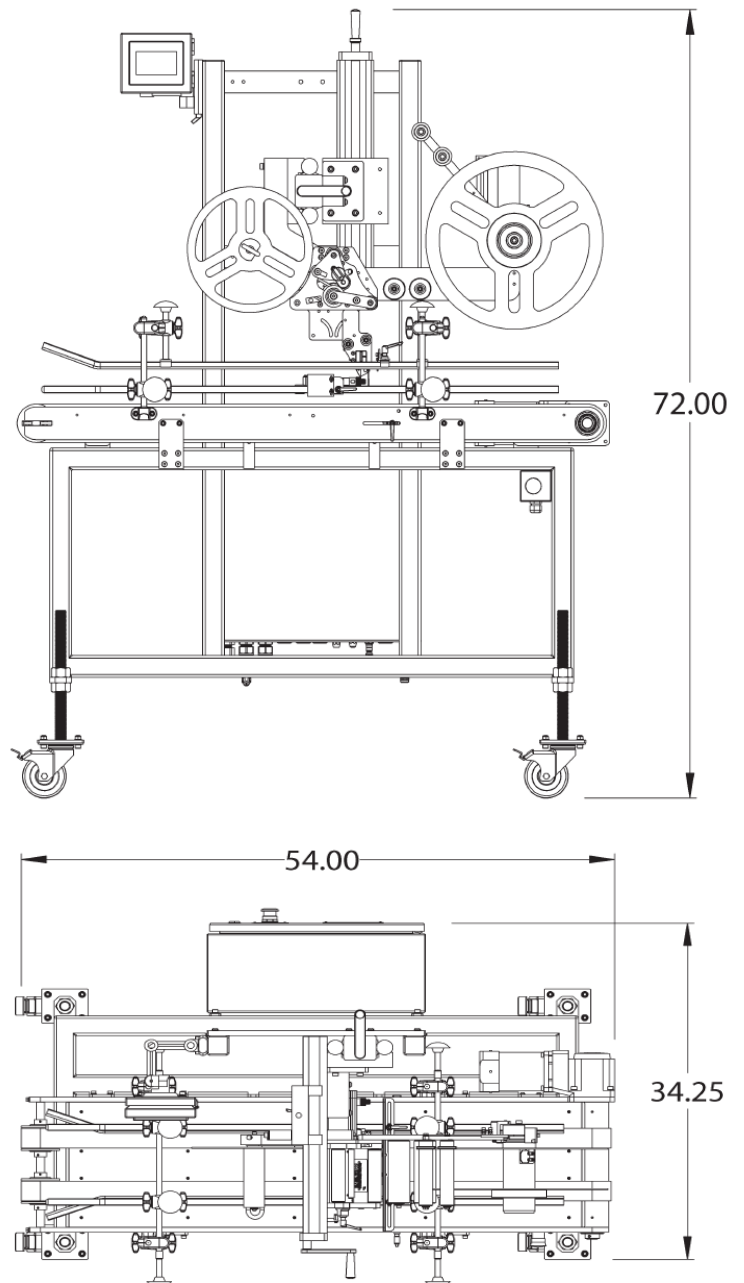

*Complimentary  
Lifetime Equipment Warranty*