

Blister machine HM 400P

High - Output - Quality Balcony Style Machine by Platen Sealing



Designed and constructed in accordance with the requirement of the pharmaceutical industry and in observance of GMP standards. Balcony style design separates entire mechanical drive systems from production feeding compartment to prevent possible cross contamination. It is designed for excellent visual and easy physical access to all area for maintenance and cleaning. This high performance model with platen sealing in dual lane is capable of high-output rate at max. 400 blisters per minute. Easy and fast changeover time of size parts by tool-less light weight design. Latest technology of servo drive system secures the most high accuracy and precise operation at entire station. Easily accessible product parameters via touch screen. PC based HMI system contributes to various kinds of control, easy monitoring, tracking the data and production and uploading the latest programming.

- Maximum 400 blisters per minute
- MMI control via industrial PC control system
- Compact floor space
- Non contact sandwich type preheating
- Platen-platen sealing station + self adjustment indexing by servo motor
- Servo-controlled blister machine
- Easy and fast format mold changeover
- Flexible discharge direction
- cGMP compliant design
- 21 CFR part 11 ensure (option)



1	2
3	4

1. Forming Station

Either thermoforming and/or cold forming can be implemented at Forming Station. Thermoforming is performed by means of air blowing on a heated film and such process allows material flexibility. Cold forming is carried out by the plug assist mechanism.

2. Feeding Section

Various feeding systems as per the product shape and character can be installed. Shift feeder leads to the best efficient filling for specific products shapes.

3. Platen Sealing Station

It is operated by servo motor drive technology which contributes to the flexibility of blister design. Such technology entails an intermittent motion for the feeding system

4. Print Registration Control System

This device controls stretching force of lid foil regularly to match the printing information on the pack by examining eyemark positions.

5	6
7	8

5. 6. 7. Self-adjusting Indexing System

The position of the film is read and corrected at each index by servo motor drive. The forming zone has individual servo-driven grips which assist the indexing system. Emboss Coding, Perforation and Punching Stations are controlled by servo-driven rotary indexing system.

8. Punching & Discharge

Horizontal punching system produces a more precise individual ejection and supports easy intergration and interface to catoner. A discharge direction can be assigned towards the front and back sides of the machine. Various discharge options are available for increased flexibility with an installation floor plan and a downstream machine.

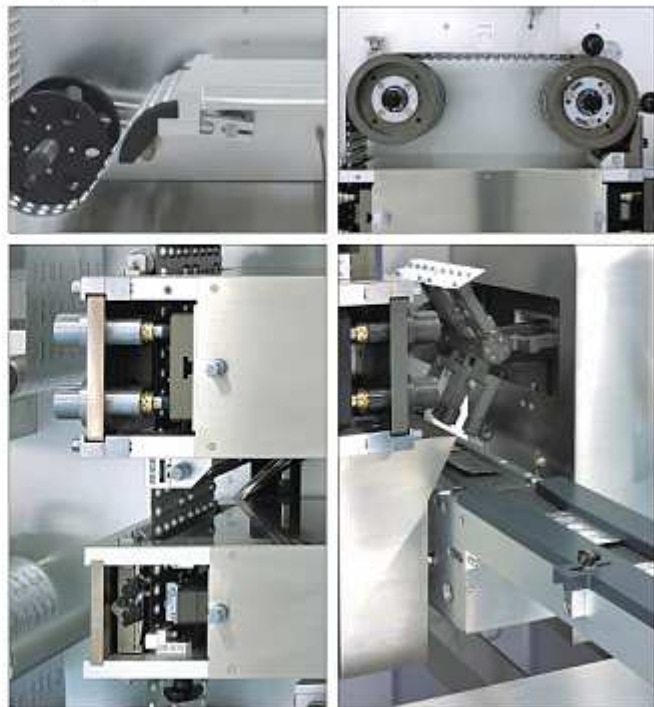

TECHNICAL DATA

Output	max. 400 blisters /min. in dual lanes	
Operation speed	Thermo forming	min. 15 - max. 70 cycles / min
	Cold forming	min. 15 - max. 50 cycles / min
	Punching	min. 50 - max. 200 cycles / min
Forming format range	Width	min. 60 - max. 270 mm
	Index	min. 30 - max. 200 mm
	Depth	max. 12 mm
Punching format range	Width	min. 60 - max. 260 mm
	Index	min. 30 - max. 100 mm
Packaging material	Forming material	PVC, PVC/PVDC, PVC/ACLAR, COC, PET, Alu forming material, etc.
	Lidding material	Alu-hard / soft, Child resistant lid foil etc.
Utilities	Electric power connection	380V, 3-Phase, 50 / 60 Hz (Other voltages available upon request)
	Electric consumption	18 KVA
	Compressed air pressure	6 - 8 bar in 10% fluctuation
	Air consumption	370 NL / min.
Machine dimensions	Length	approx. 4,280 mm
	Width	approx. 1,450 mm
	Height	approx. 1,800 mm
	Weight	approx. 3,500 kgs

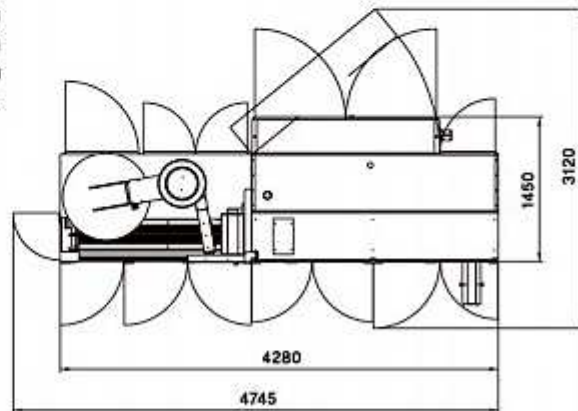

Contents on this catalogue are to assist understanding of the machine only and are subject to technical modifications without prior notice. The final specification is as per our quotation offered to you exclusively.