

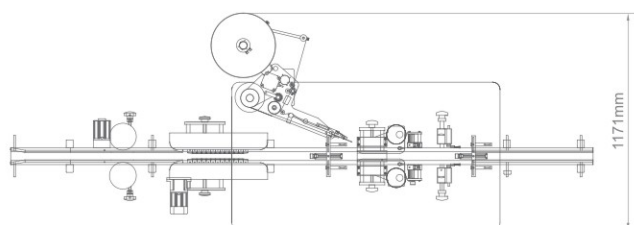

HYL-410

Single Side Labeling Machine

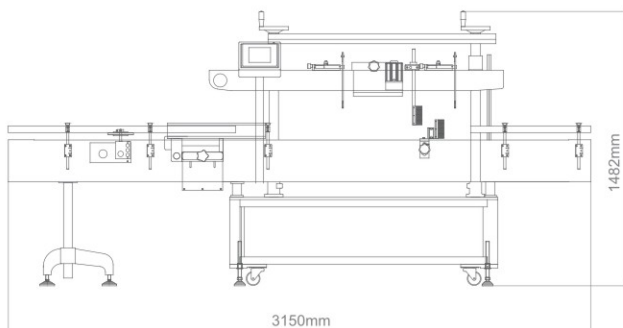

Product Descriptions

It is used for single-side automatic labeling of oval and square products in food, medicine, daily chemical and other light industry. Through the optional roll belt, the cylinder positioning way or the turntable positioning can at the same time complete the functions of labeling, labeling and the like of the round bottle.



Functions & Features

- The multi-purpose labeling machine is used for a wide range of applications. It can be attached to the side with a simple adjustment, and the circumferential stickers can be converted to each other.
- One machine can complete three types of side labeling, square bottle, flat bottle, round bottle, and horizontal labeling.



- Designed for irregular, curved surfaces such as flat, square, etc. to ensure labeling precision and effectiveness.
 - Double side chain correction device ensures bottle neutrality.
 - Special elastic pressing device to ensure the stability of the bottle.



- Optional transparent label-specific detection of the electric sensor to improve detection precision.
- Optional positioning and other devices to achieve special positioning and labeling requirements for round bottles.

Technical Parameters

Items	Specifications
Bottle size	The length and width range from 20-90mm, and other sizes need to be evaluated by Huiyi technology Company.
Bottle appearance	Single side labeling: square, flat, oval bottle Square bottle wrap: a rectangular or square bottle with a circular cap or bottle neck as the center of symmetry. Asymmetric bottles need to be evaluated by Huiyi technology company
labeling speed	Mode: (A): 80 bottles / min, mode (B): 50 bottles / min Mode (C): 120 bottles / min, mode (D): 120 bottles / min
labeling precision	±2mm Excluding bottle and label error
Power	220VAC±5% 50Hz 1KW
Dimension (L x W x H)	3.150mm x 1.171mm x 1.482mm



Sunflower Technology Co.,Ltd

Add:3rd Floor, No.1 Xiayuan Shichang Road, Huangpu District , Guangzhou,China.
Tel: 0086 20-8202 2007 Fax: 0086 20-8206 1056
Email: info@sunflowerpack.com Web:www.sunflowerpack.com

