

P harma Lifter-Between Floors

NTC Series



Pharma Lifter-Between Floors

NTC series Pharma Lifer is mainly used in pharmaceutical industry for transferring solid dosage materials (in bulk, sachet, bag, tank, etc)between floors. Applying the NTC series Pharma Lifter has optimized the producing flow, avoided dust and cross pollution. It's the desirable transferring equipment in pharmaceutical industry for solid dosage sector. Meanwhile, it can be widely used in such areas as raw medicine material industry, chemical industry, foodstuff industry. etc.



Features:

- Max load: 2000 kg.
- Special design for material transfer between floors.
- Safe and stable performance.
- Ease of handling of material in bin, drum or bag.
- Labour saving.
- Anti-falling system.
- Safety lock.
- Remote control.
- cGMP compliant



Dimensions:

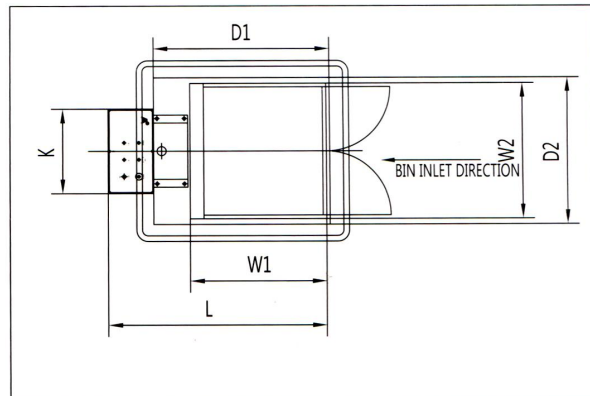
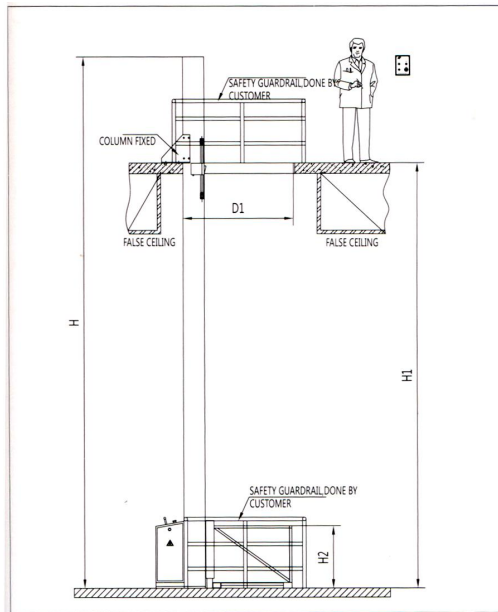

Technical Data	NTC200	NTC300	NTC400	NTC600	NTC800	NTC1000	NTC1200	NTC1500	NTC1800	NTC2000
H (mm)	H1+1500	H1+1500	H1+1500	H1+1500	H1+1500	H1+1500	H1+1500	H1+1500	H1+1500	H1+1500
H1 (mm)	6000	6000	6000	6000	6000	6000	6000	6000	6000	6000
H2 (mm)	880	880	880	880	880	880	880	880	880	880
K (mm)	750	750	750	750	750	750	750	750	750	750
L (mm)	1720	1720	1720	1920	1920	2120	2120	2120	2140	2140
W1 (mm)	1000	1000	1000	1200	1200	1400	1400	1400	1400	1400
W2 (mm)	1000	1000	1000	1200	1200	1400	1400	1400	1400	1400
D1 (mm)	1350	1350	1350	1550	1550	1750	1750	1790	1790	1790
D2 (mm)	1100	1100	1100	1300	1300	1500	1500	1500	1500	1500
Net Load(Kg)	200	300	400	600	800	1000	1200	1500	1800	2000
Total Power(Kw)	3	3	3	3	3	3	3	3	3	3

SaintyCo also offer:

Encapsulation Solutions

Tablet Compression Solutions

Coating Systems

Cartoning Systems

Blister Packing Solutions

