



## *Model TruSort-48 Bottle Unscrambler*



Automatic Bottle Unscrambler – Model TruSort-48 is capable of feeding and orienting plastic and metal containers.

### **Construction Features:**

- Heavy duty frame built with 2 x 2 x 0.187 square tubes.
- Adjustable positioning on most systems to minimize change parts requirements.
- 48-inch diameter pre-feeder will accommodate a wide range of containers, one inner disc is included.
- Capable of handling a wide range of containers, from ounces to gallons. • Rotating bottle reject with speed control included.
- Calibration markings, labels and indicators to help document changeovers.
- Bottle turning by pneumatic actuator to guarantee production speeds.
- Pre-feeder built at an angle to minimize bottle damage.
- Single hand wheel adjustment for intake and delivery carrier belts, additional tweaking is also possible.
- Spacing belt for bottle feeding and spacing, gear motor driven.
- Delivery carrier belts have additional adjustments to guarantee container placement on conveyor.
- Single gearbox for main belt system eliminates all the belts and springs of the transmission system, powered by  $\frac{3}{4}$  Hp motor.
- Bottle handling from left to right.
- Cad designed, CNC manufactured, thoroughly tested before leaving our facility.
- Low electric and pneumatic consumption.
- Various hopper sizes available depending on specific application.
- Can work on existing or new conveyors.
- Leveling by mounting screws.
- Guarantee: 18 months on all parts under normal use, except belts.

### **Electric and pneumatic requirements:**

- 220 Volts, 60Hz, 10 Amps • 5 CFM @ 80 p.s.i.

DRAWING:

Trusort-48

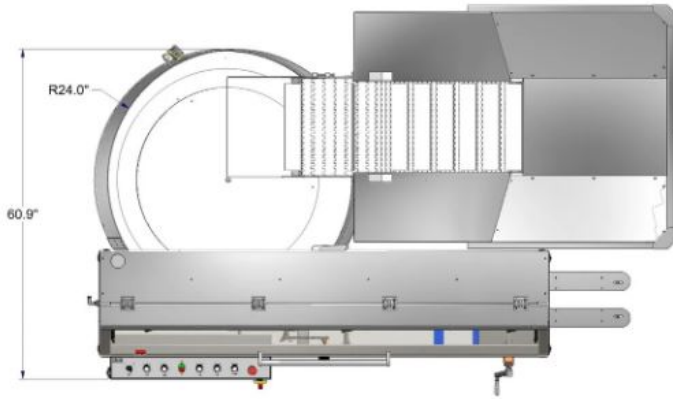

35 Cubic Feet Hopper

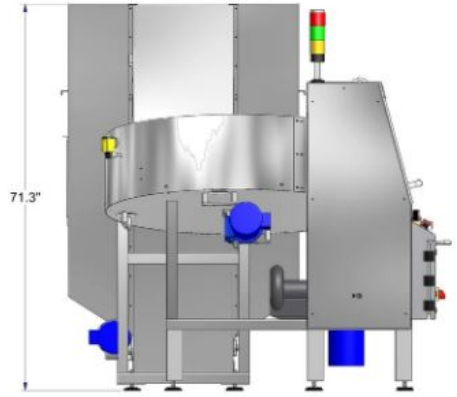

MACHINE MODEL: Trusort-48  
MACHINE CAPABILITIES:  
PRODUCTION SPEED:  
OPTIONS:

**ACASI**  
MACHINERY INC

WEIGHT: SCALE:  
DATE: 4/19/2012

PAGES: 1  
DIB:  
BY: Cesar  
DATE: 4/19/2012

1 2 3 4 5 6 7 8 9 10 11