

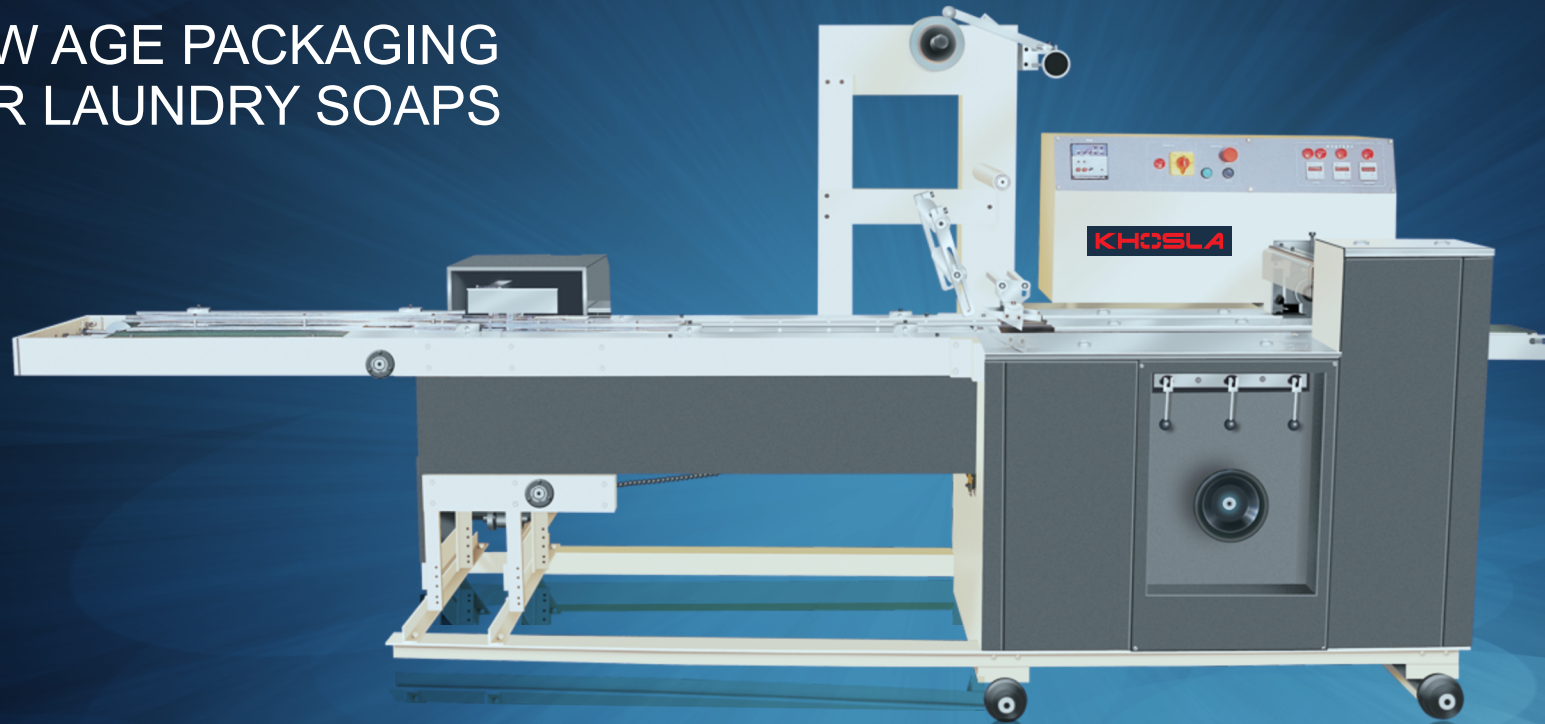

KHOSLA
listen innovate deliver

NEW AGE PACKAGING FOR LAUNDRY SOAPS



FINSEAL 2040

Pouch pack machine for laundry soap
(100g/500g/800g/1Kg packs, etc.)

FINSEAL 2040

Pouch pack machine for laundry soap (100g/500g/800g/1Kg packs, etc.)

1 Day Finseal 11 MP Output = Productivity of 15 Men



FINSEAL 2040 is a horizontal form fill and seal machine specifically designed to wrap Laundry Soaps either individually or in groups in a three side sealed pouch. The Machine has indexed belt infeed which can either be directly connected to the discharge belt of the upstream machine which is running at the matched speed, or can be manually loaded. All drives are primarily mechanical. Automation skill level is therefore, not required for maintenance of this machine.

Standard Features

- Integrated autofeeder for feeding soap in the machine.
- All surfaces on which soap is transported are made of stainless steel.
- Long seal is formed by means of three pair of rollers, axes of which can be tilted to get best result.
- Torque slip clutch to prevent damage in case of accidental damage.
- Low voltage heaters for safety.
- Individual PID temperature controller for heater.
- Print registration unit for printed wrappers.
- Heavy distortion free cast structure.

Optional Features

- Variable speed drive.
- Change parts.
- Centralised lubrication unit.
- Tool Kit.
- Emergency spares.
- Mirror image orientation to allow single operator to run two machines.

pecially designed for Laundry Bars & Detergent Bar or Cartonned Products. Multi-soap pack.



120 PPM for Single Pack
60 PPM for Multiple Pack



Hi-Speed

Technical specifications may vary because of continuous development.

Product Size (in mm)

	L	W	H
MIN.	60	40	25
MAX.	220	100	65

- All minimum and maximum sizes are not valid at same time
- Other dimensions can be considered on request.
- Power: 2.5 KW/440V, 3 Phase, 50/60 Hz

Machine Layout

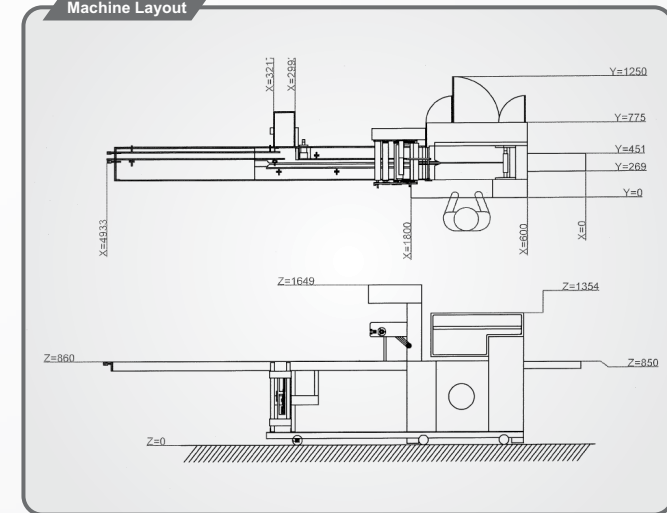

KHOSLA
listen innovate deliver

Khosla Precisions

93 Industrial Area, Ph-I, Panchkula 134108, Haryana, INDIA

Telefax: 91-172-2562664

E-mail : info@khoslamachines.com

www.khoslamachines.com