

Automatic packaging machine DK-1412/1422

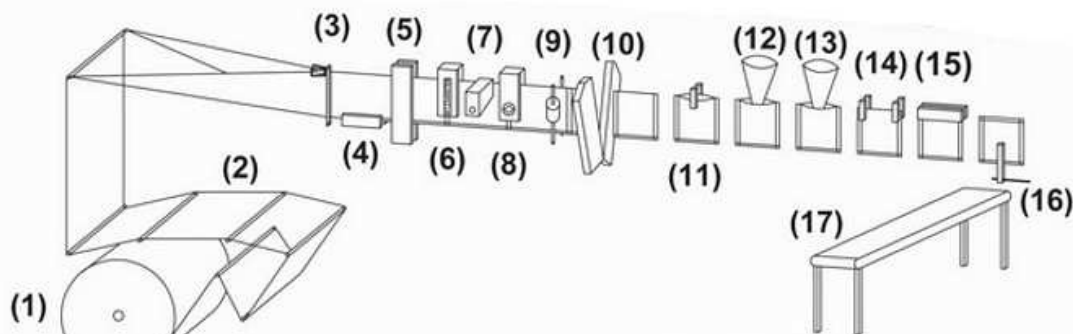

Simplex/Duplex Mode with Two Filling Stations



01. 紙捲氣漲軸 Film Reel Expanded Roll
(最大可支援直徑 450mm)
02. 紙捲張力控制裝置 Film Tension Control
03. 銀邊糾偏調整裝置 Film Edge Control
04. 底部封口裝置 (選配) Bottom Sealing Unit
05. 側邊封口裝置 Vertical Sealing Unit
06. 日期鋼印裝置 Emboss Coder (最多可放17個字)
07. 電眼定位裝置 Photo Mark Registration System
08. 易撕口裝置 Tear Notch Device
09. 伺服送紙裝置 Servo Film Feeding System
10. 裁切刀裝置 Independent Cutting Device
11. 真空吸盤及氣吹式開袋裝置
Vacuum Assisted Pouch Opening with Air Blowing
12. 第一充填下料站 First Filling Station
13. 第二充填下料站 Second Filling Station
14. 獨立機械式開袋裝置 Static Stretching Unit
15. 上封口裝置 Top Sealing Unit
16. 出口機械手臂 (選配) Front Load Transfer
17. 出口集合計數輸送帶 (選配)
Outlet Counting/Grouping Conveyor

FEATURES:

1. Machine by Full CAM Design, running high speed with high stability.
2. Operating Interface in Chinese/English.
3. Servo Film Feeding System, High Accuracy Photo Mark Registering.
4. Easy Size/Format Change within 30 minutes.
5. Available with Servo Auger Filler, Cup Filler, Piston Filler, Vibratory Feeder, Multi-Head Weigher, etc.
6. Including Hopper Level Detector available with Various kinds of Auto-Feeding System.
7. Including Various Detect Function, like End of Reel, Jointed Tape, Hopper Level, Photo-Mark Fault, No Open/No Fill, Empty Pouch Reject.

Filling System:

1. Auger Filler
2. Liquid & Paste Filler
3. Solid Vibratory System
4. Volumetric Cup Filler
5. Weighing Filling System
6. Tablet Counting/Filling
7. Capsule Counting/Filling