



Horizontal Merge LABELER

Labelers for Horizontal Form Fill & Seal Machinery



Whether you need to apply labels to the inside or outside of the package our solution is to correctly integrate the labeler to your wrapper. The system is designed specifically for your packages and label requirements. With the wide range of wrappers on the market and the custom design for products produced on them, it is critical to ensure you have the right labeler for your application. At EPI we take the time to review your needs and to design and produce our labeler to meet your application requirements. Whatever you are wrapping: cookies, muffins, candy, popcorn, biscuits, multi-packs, chilled or frozen meats, etc; EPI can design a system to apply various types of labels to these packages such as primary, nutritional, flavor, or recipe booklets.



COMPATIBILITY

Mounting kits available to fit vertical form-fill-seal equipment manufactured by:

- Bosch
- Fres-Co
- Hayssen
- ICA
- Ilapak
- Ishida
- Key-Pac
- Masipack
- Matrix
- Rovema
- Sandiacre
- TNA
- Triangle
- Universal
- Viking Masek
- Woodman
- Wright
- Many More



HORIZONTAL MERGE LABELER

TYPICAL PRODUCT SPECS

- Label Size:** 1"x1" to 5"x12".
Smaller/larger size optional
- Label Supply:** 12" OD on a 3" Core.
Larger size optional
- Electrical:** 2A @ 120VAC, 60HZ.
Different supply voltage optional
- Speed:** Variable up to 100 FPM.
Higher speeds optional
- Mounting:** Mounting kits available
to fit horizontal form-fill-seal
equipment manufactured by
almost everyone

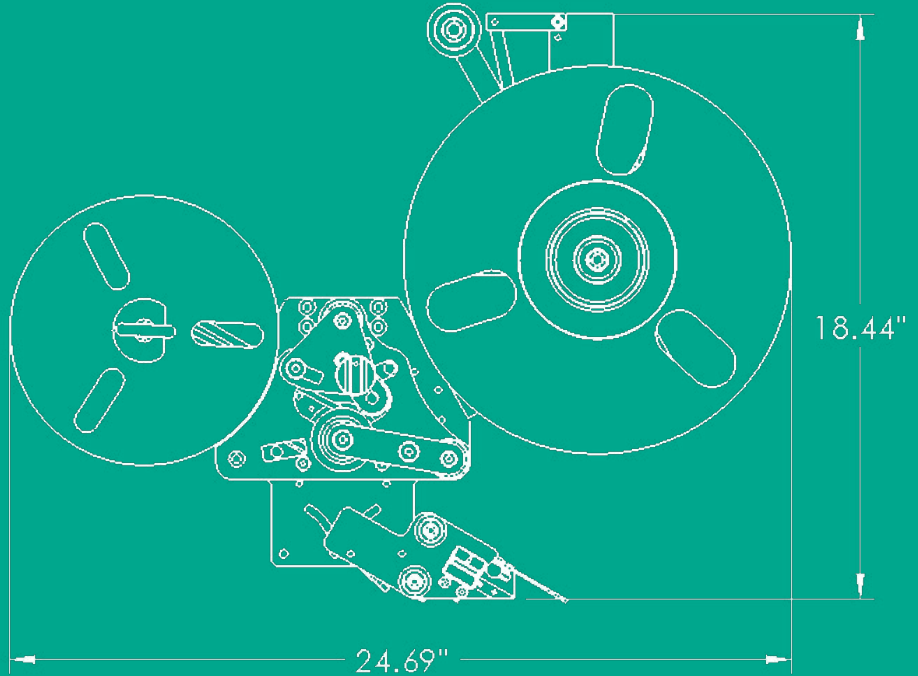

Measurements in inches.

WHY EPI?

For over 35 years EPI Labelers have been designed and engineered for reliability and ease of use. We take the time to understand each application and listen to our customers needs. Let us show you how precise thinking and simple design can help you.

RELIABLE

EPI Labelers are built to stand up to the daily use and harsh environments that come with the territory. Enclosed direct drive technology along with corrosion resistant material allows our labelers to work in dusty, wet and cold packaging operations with a minimum amount of maintenance required. Your operators and mechanics will appreciate EPI Labelers ease of set up and use.

VERSATILE

Sure, EPI Labelers are easy to set up and operate, but the versatility that is engineered into all our equipment allows you to use our labelers in a variety of applications. Whether your job calls for a non-contact vacuum/blow, tamp or two panel application we can configure our labelers to meet your needs.

QUICK AND EASY SETUP

Our customers tell us that EPI Labelers give them the ease of use that they have not experienced with other labeler equipment. The cantilevered design lends itself to easy threading and the simple mechanical adjustments needed to change label size make EPI Labelers a favorite of mechanics and operators everywhere.