

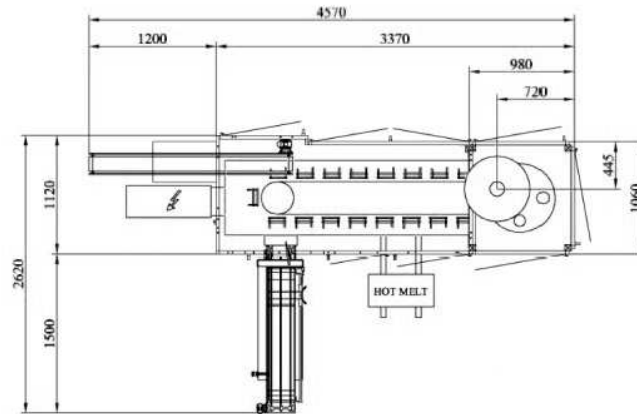

SPECIFICATIONS

MODEL	NB/85
Carton Dimension - Height	110 min/300 max
Carton Dimension - Thickness	25 min/75 max
Carton Dimension - Width	70 min/180 max
Free air consumption	120 NL/1'
Input power	8 Kw
Operating pressure	6 Bar
Production speed	100/1' max
Weight	Kg. 3220



Description

This belongs to a series of cartoning machines of medium production speed for small and medium cartons. Suitable for packing granular products, powders, pasta and others by volumetric dosings or electronic weighers. It may be equipped for the packing of single or in groups bags, bottles, etc. This smartly resolves the problems of those companies that have to pack numerous types of cartons in that the format change-over is done in a few minutes without the need for specialized staff. Simplicity and a robust structure have permitted to be highly regarded for more than 30 years. The continuous technological updating with the most recent technical innovations grant secure packaging and the best quality.

Operation

The flat cartons are loaded on the blanks magazine and automatically conveyed to the forming up system. The cartons, once in the machine, undergo marking on the outside flap, glueing and closure of the bottom, before reaching the filling zone. Filling is carried out with a system suitable for the client's product. The carton carries on to be glued and to be closed for good on the upper side and finally transferred to the way-out line. It is also complete with:

- Regulation of production speed with electronic system.
- Size change regulation.
- Automatic regulation of product weight or volume.
- Automatism and checking of production and feeding.
- Electronic device controlling the glue application.
- Accident prevention protections as according to law with CE mark.

Optional

- Check weigher: electronic with dynamic weighing and possible local or remote printer.
- Out tolerance carton ejector.
- Gluing: cold glue or HOT-MELT standard with or without Sift proof.
- Filling: with volumetric dosing, multi-headed electronic weighers, counter units or similar.
- Special loaders for plastic containers, bottles and glasses.
- Automatic dispenser of leaflets, small envelopes, coupons, etc.
- Tuck-in closure without glue.
- Personalize special closures.
- Introduction system of single and multiple bags.