

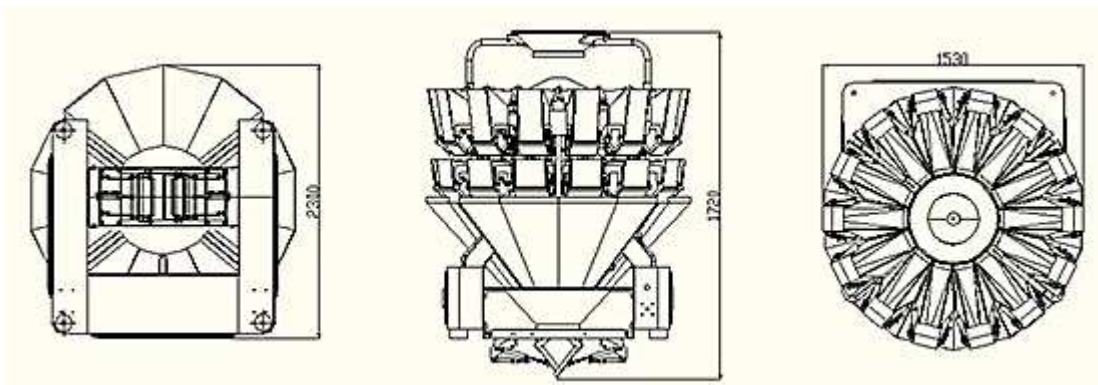

## Z-T(P)14L5.0 14 Head Multi-head Weigher



Z-T(P)14L5.0 14 Head Multi-head Weigher is suitable for weighing of light weight, big volume materials and big target weight like large of nuts, vegetable, salad.



### Main Features:

1. Original program can be restored.
2. Easy cleaning and maintenance with clean function, all hoppers can stay open
3. Piece counting function
4. IP65 certificate
5. Unqualified weight reject
6. Step motor angle can be set according to different product
7. 99 program can be preset

## Special Features:

1. Modular electronic system makes function expanding and maintenance easier and at lowest cost
2. Professional A/D card with high accuracy and stability. Interchange is available
3. HMI program with different authority management more user-friendly
4. HMI program can be upgraded by U-disk
5. PLC control system applied in the weighed and it makes machine more stable and low fault rate. Functions expanding more easily.
6. Application software can be upgraded by memory card.
7. Remote control is available.

## Technical Specifications:

Model	Z-T(P)14L5.0
Weighing Range	10-5000 g
Weighing Accuracy	±0.1-3 g
Max. Weighing Speed	120WPM
Hopper Volume	5.0L
Operation Panel	10.4 inch touch screen
Control System	MCU or PLC (Siemens or Rockwell Allen Bradley)
Power Supply	AC220V ±10% ,50Hz(60Hz) 2KW
Packing Dimension	2300(L)×1530(W)×1720(H)mm
Net Weight	597 kg
Packing Weight	597 kg