

P_{rimaFill} CF 25

Capsule Filling Machine



Capsule Filling Machine

The **PrimaFill CF 25** Capsule Filling Machine is an intermittent motion, automatic hard gelatine capsule filler with an output of up to 25,000 capsules/hour, designed for filling hard gelatine capsules ranging in size from 0# to 4# with powder or pellets, size 00# & 5# are available as an option.



PrimaFill CF 25

Features:

- High speed: up to 25,000 capsules/hour
- Contact parts made of stainless steel
- Siemens PLC and touch screen control
- Enclosed main turn table avoid dust getting into mechanical parts.
- Vacuum cleaning station for segment cleanup in each cycle.
- Efficient capsule separation by means of vacuum.
- Automatic control for capsule and powder supply.
- Safety interlocked guarding
- Alarm for door open
- Alarm for lower level of powder
- Alarm for lower level of capsule
- Fast changeable of mould
- Build-In vacuum pump
- cGMP compliant
- CE Marked

Optionals:

- Pellet filling device

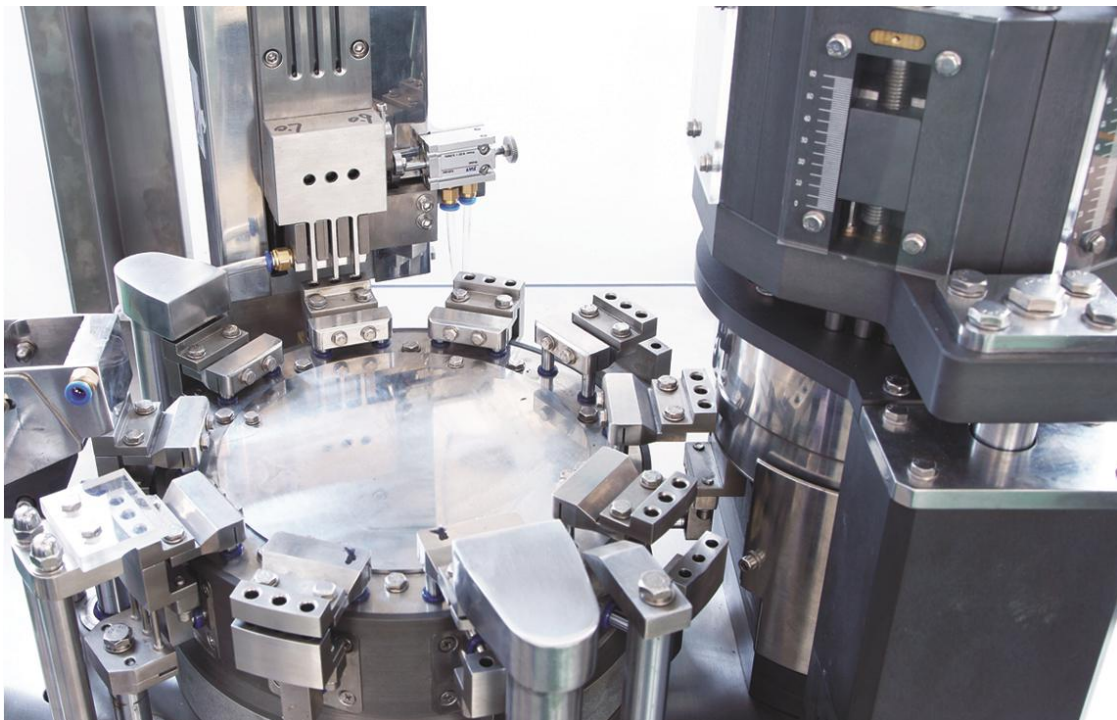

Dimensions:

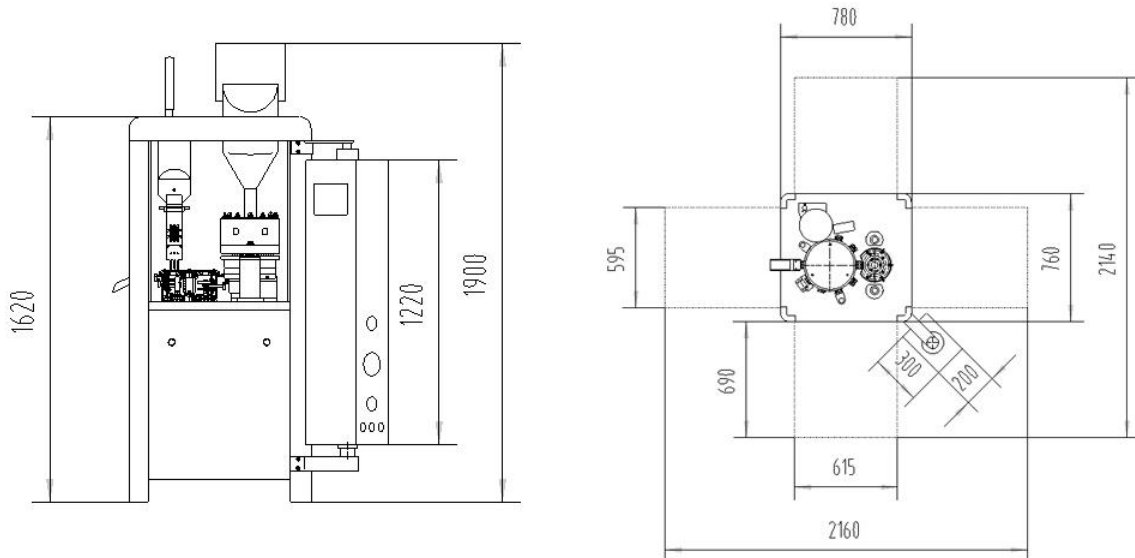

Technical Data	PrimaFill CF 25
Number of stations	10
Number of segment bores	3
Application range	Capsule sizes: #0, #1, #2, #3, #4 (option #00, #5) Each size requires a set of capsule tooling.
Max. output (pellet filling)	3,000-17,000 capsules / h (actual speed depends on formulation characteristics, filled weight, capsule size .. etc)
Max. output (powder filling)	6,000-25,000 capsules / h
Power source	380/220V , 3 pH , 60/50Hz
Power consumption	3 KW
Machine dimensions	760(L) x 780(W) x 1800(H) mm
Machine Weight	800 Kg (approx)

SaintyCo also offer:

Encapsulation Solutions

Tablet Compression Solutions

Coating Systems

Cartoning Systems

Blister Packing Solutions

