

NTP-30(50)

MAIN FEATURES

- 3 in 1 single cell technology - form, load and seal on one frame
- DELTA Style 2 axis robot - maintenance free design
- Top load up to 30 trays/cartons per minute
- High speed top load up to 50 trays/cartons per minute available
- Flexible forming funnel, accomodates material variance/imperfection
- Tool-less changeover - under 5 minutes
- Smallest industry footprint
- Stainless steel frame STANDARD
- Washdown available



SINGLE CELL TRAY PACKER

• Affordable • Efficient • Practical

NTP-30(50)

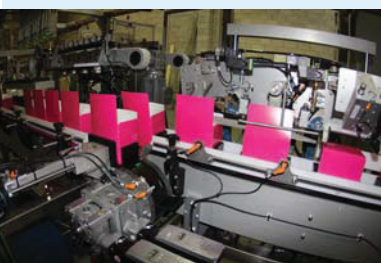
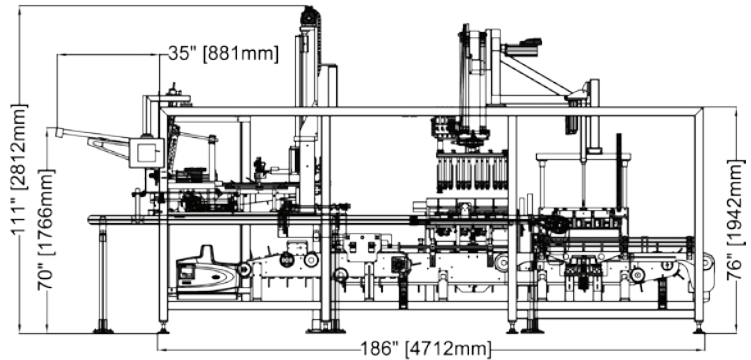
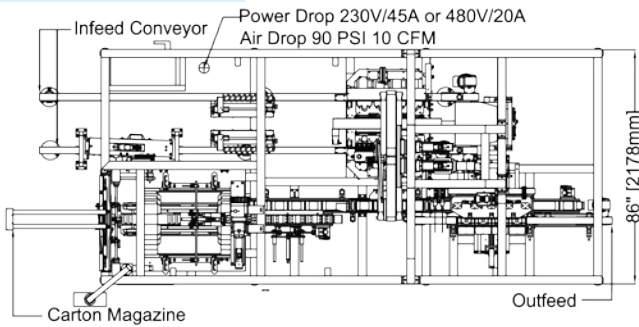

SPECIFICATIONS:

DRIVE:	AC Motors (product transfer), Servo Drives ("Delta" Loader, Tray transfer)
SPEED:	Up to 30 cartons/trays per minute High speed up to 50 cartons/trays per minute available
PRODUCT SIZE RANGE:	Per Project Specification
TRAY SIZE RANGE:	Per Project Specification
TRAY SEALING:	"Nordson" Glue system
MAGAZINE CAPACITY:	2 ft. (~700 blanks)
FRAME:	Stainless Steel
GUARDING:	Full length polycarbonate with extruded anodized aluminum frames
FINISH:	All parts in contact with product are stainless steel, anodized aluminum or plastic
ELECTRICAL:	- Schneider Electric, Allen Bradley, Omron - Color touch screen HMI - NEMA 12 wiring and enclosures - 3-Color stackable warning lights
PNEUMATICS:	"FESTO"
INSTALLATION REQUIREMENTS:	Power: 230 VAC/30 Amps. or 480 VAC/15 Amps. 3 phase, 50/60 Hz Air: 90 PSI, 10 cfm



1111 Flint Road, Unit 29, Toronto
Ontario, Canada, M3J 3C7
Tel: (416) 663 7071
www.nuspark.com

Distributed by