

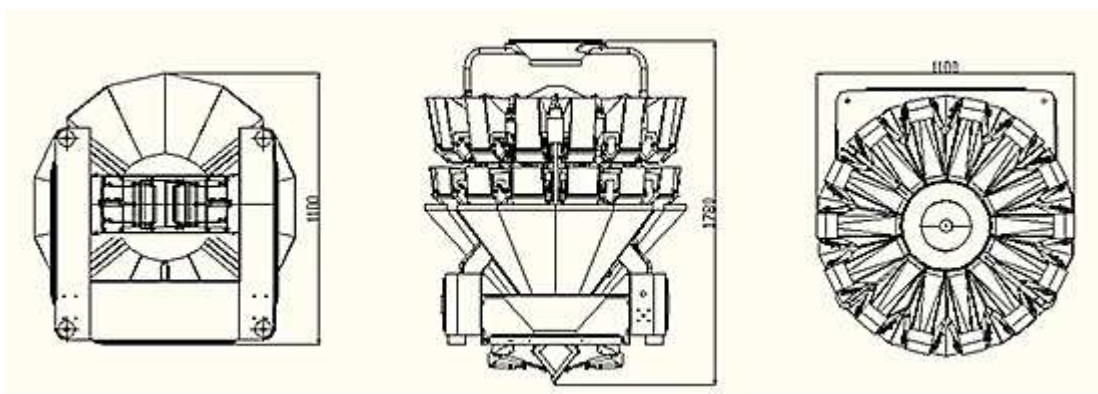

## *Z-T(P)32(20 24)L1.6(0.8 2.5) Multi head Weigher*



Z-T(P)32(20 24)L1.6(0.8 2.5) Multi head Weigher is suitable for weighing of granule, slice, roll or irregular shape materials such as cereal, pasta, candy, seed, chips, coffee bean, nut, puffy food, biscuit, chocolate, pet food, frozen foods, etc. It is also suitable for non-food industry such as screws, bolts and plastic components.



### **Features:**

1. Blending scale from 20 head to 32 head with adaptable 0.8 liter, 1.6 liter, 2.5 liter and 5 liter bucket, ideal for 2 to 8 kinds of products blending.
2. Products blending ratio and target weight are within precision control.
3. Can be interfaced to various packaging machines and conveyor systems.

4. Integrated blending scale takes less space and easy to manage comparing to multiple scales solution.

**Technical Specifications:**

<b>Model</b>	<b>Z-T(P)32(20/24)L1.6(0.8/2.5)</b>
Max. Cap.(g)	10-1000g
Weighing Accuracy	±0.1-2g
Weighing Speed	30~80WPM
Hopper Capacity	1.6L(0.8/2.5)
Operation Panel	10.4 inch touch screen
Control System	MCU/PLC
Power Supply	AC220V±10%、50/60Hz、3KW
Packing Dimension	2300(L)*1530(W)*1720(H)mm
Net Weight	820KG
Packing Weight	900KG
Optional Devices	Dimple plate/Timing dipper/ Diverter device /Teflon paint