



ROTARY ROFS-1012-SS-XXL



Rotary ROFS-1012-SS-XXL

- Stainless Steel Construction
- Six (6) Stations
- Centralized Adjustments For Gripper Width
- Bag Width 7.87" To 15.75"
- Bag Length 11.81" To 21.65"
- Max Speed 20 ppm
- Max Filling Weight 10 lbs.
- Pouch Material = Laminated Film, 3 – 5 mil thickness range
- Pouch pattern = Flat, Stand-Up, Zipper, Slider-Zipper, Gusset Pouch
- User Friendly Color Touch Pad
- Bag Magazine
- Bag Opening Blade With Full Opening Detector
- Bag Deflator
- Discharge Conveyor

Optional Equipment

- Zipper Opener
- Date Code Printer, Embossed On Ribbon
- Product Settler
- Gas Injection
- Filler/Weigher – Ask For Quote

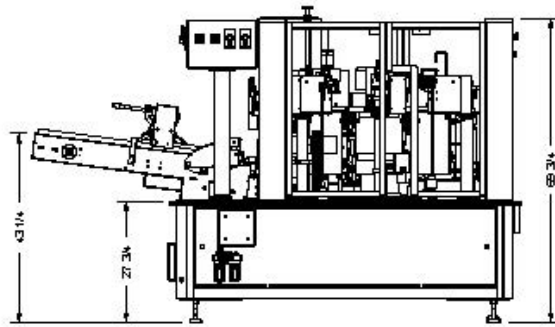
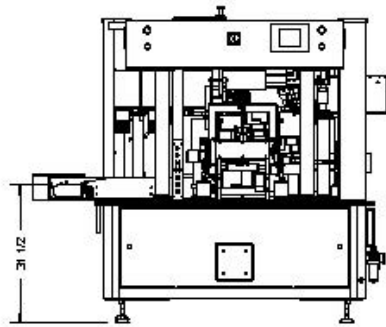
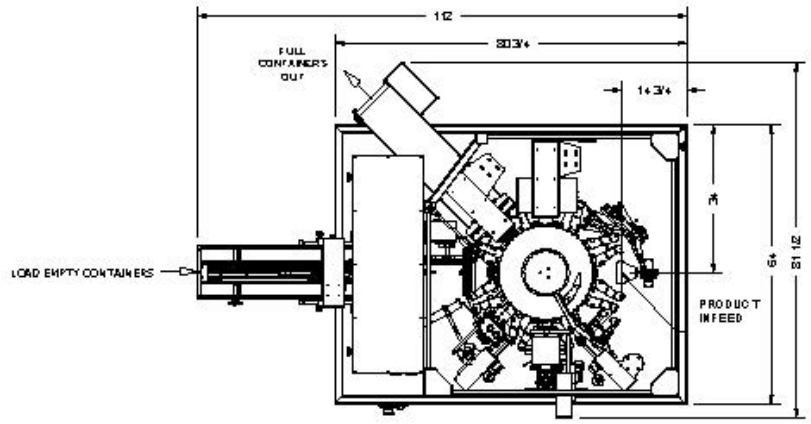
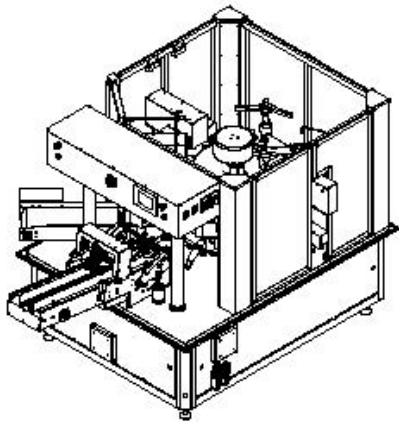

Electrical Requirements:
 A. (1) 15A 220V AC Three Phase @ 60Hz

Air Requirements:
 B. 18CFM @ 85PSI

DESIGN	4/17/2015	Clean Packaging	
DATE		TITLE	
BY		Rotary Pouch System	
APPROVED		SIZE	DWG NO.
		A	ROFS-1012
DESIGN/ENGINEER/DES	SCALE		