

Drum Lifting Column-Movable

NTY Series



Drum Lifting Column-Movable

NTY series Pharma Lifter is mainly used in the solid dosage production procedure for transferring and discharging materials, consequently it is operated with corollary equipments such as blender, mill facility, coater, tablets press, capsules filling machine, etc. Pharma Lifters, movable are widely used in pharmaceutical, chemical, foodstuff industries, etc.



Principle:

This equipment is composed of chassis trolley, lifting and drum inversion systems. When operating, lock first the drum with the cone adapter, then press "Raise" button to raise the drum. When it's raised in position, press "Invert" button to invert it 180° and align the Pharma Lifter, movable to dock to the inlet of the next processing equipment, and then open the butterfly valve to discharge the materials.

Features:

This equipment is successfully designed on the basis of a wide research, absorption and digestion of foreign advanced models. It has a reasonable structure with stable performances and easy operation; the whole machine has no dead angle or exposed screws. To ensure a safe production, it is also designed with a device avoiding misoperation of the butterfly valve which is easy to dismantle and wash. Consequently, powder dust or cross pollution are effectively controlled to optimize the production process. NTY Series Pharma Lifters, movable comply entirely with GMP requirements for medicine production.



Dimensions:

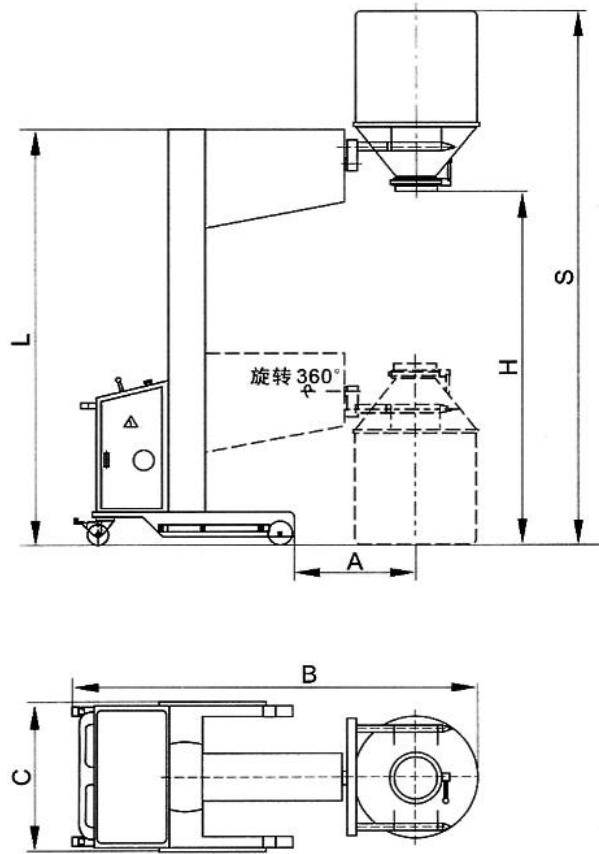

Technical Data	NTY50	NTY100
A	500	600
B	1700	2000
C	650	750
L	1950	1950
H	1800	1800
S	2570	2750
Load(kg)	50	100
Power(Kw)	0.75	1.5
Weight(kg)	310	420

SaintyCo also offer:

Encapsulation Solutions

Tablet Compression Solutions

Coating Systems

Cartoning Systems

Blister Packing Solutions

