

DPH-320 Blister Packing Machine

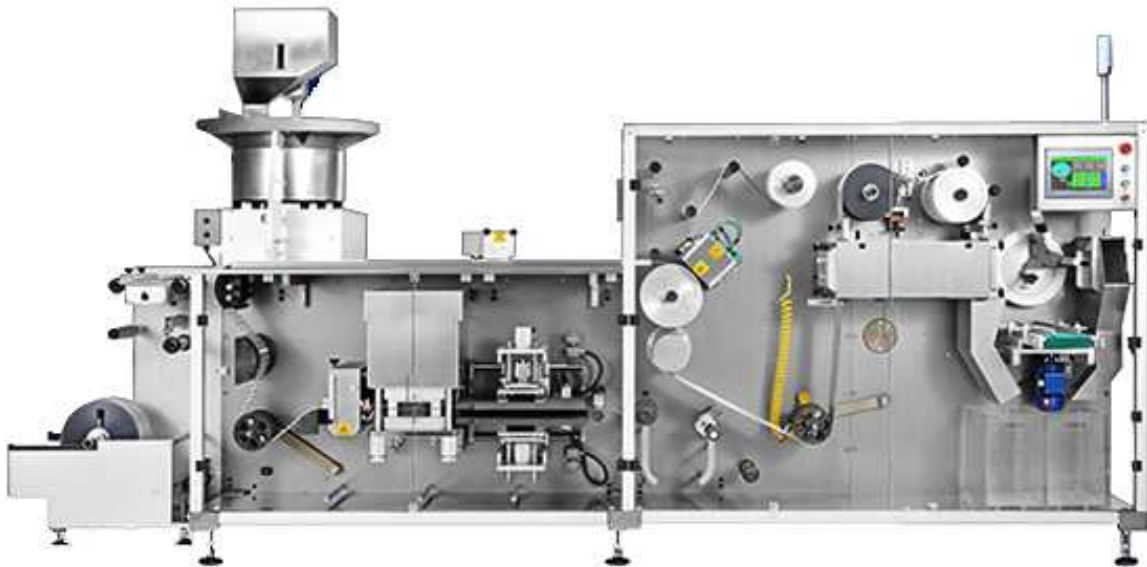

Introduction of DPH320 Alu-Pvc Blister Packing Machine

1. Brief introduction:

DPH320 High Speed Alu-Pvc blister packing machine is the new high-tech production combined with domestic and abroad experiences manufactured by Double Crane Equipment company. DPH320 adopts complete servo motor driving system, can complete accurate control, low noise, high speed of production, easy changing of model, accordingly achieve high-efficiency automatic medicine packing, minimum personnel and material cost. DPH320 can guarantee the process of medicine packing completely meet the GMP requirement.

2. Application:

DPH320 Alu-Pvc blister packing machine has a wide-ranging application. It is mainly used for medicine (tablets, capsules, pills special-shaped tablets), food and other similar solid things. It packs the medicine into the bubble between the PVC and Alu foil, can satisfy the different blister shapes required by different customers.

DPH320 combined two advantages that plate forming has good efficiency and roller heat sealing has high speed. It makes the forming in low speed while sealing, batch number, perforation, cutting in high speed 15 meters per minute through reasonable speed matching. The production speed has acquired a lot of promotion, in the meantime, the performance is more reliable.

DPH320 Alu-Pvc blister packing machine adopts plus pressure, makes the bubble symmetrical and full. The heat sealing part adopts netlike heat sealing, stable and reliable. Cutting part adopts no-scrap cutting model, can save packing materials. Each station uses the Schneider servo drive, accurate control, guarantee the reliability of running. The multi feeding systems of this machine can meet the requirement of various tablet shape.

3. Main technical data:

Machine	DPH320 Alu-Pvc Blister Packing Machine
Max design speed(Cut/min) According to blister size	250
Max material line speed	15
Max forming depth	12
Max forming depth (belt width×index)	320×260
Max index length	260
Max material width	320
Max cutting length	100
Power	Supply:AC380V/3-Phase/50Hz Consumption:about 20Kw
Air	Pressure:0.6-0.9MPa Consumption:<15 m3/h
Water	Temperature: 15-20oC Water:about 0.2 m3/h
Dimension (including feeder, L×W×H) (mm3)	4750×1680×2200
Weight	About 4000

Packing material:

Heat forming film and composite material, such as PVC,PVDC

Specifications of PVC:

Thickness 0.25-0.35mm Max width 320mm

Reel internal diameter 75-76mm Max reel diameter 600mm

Single side glued Alu foil

Specifications of ALU:

Thickness 0.02mm Max width 320mm

Reel internal diameter 75-76mm Max reel diameter 240mm