



— Pharma Process & Packaging

www.saintyco.com

T ablet and Candy Roll Wrapping Machine



CATALOGUE

Tablet and Candy Roll Wrapping Machine

TR-150 Tablet/Candy Roll Wrapping Machine is designed and suitable for wrapping in on roll with several pieces of tablets by aluminum foil & paper laminated material. All movements of the machine adopt advanced PLC controller and Servo motor, so it is very stable and reliable, operation easy and maintenance convenience.

It can run full automatically, warning and stop function for no wrapping paper and not tablet, all tablets touching material adopts excellent SUS304 stainless steel (or SUS306), other steel material adopts enamel paint or Alloy to combine.



TR-150

Composition and function:

- Vibrating tablets feeding unit: put tablets into hopper by manual, vibrating system will send tablets into track automatically for wrapping preparation, automatic stop for overload tablet, automatic start for lack of tablets, all tablet arrangement is automatically.
- Tablets arranging unit: this unit is to arrange tablets according to setting position and quantity for pushing to wrapping station.
- Wrapping paper feeding unit by servo motor: put the wrapping paper to holder machine can arrange wrapping paper to wrapping station for standby automatically.
- Controller unit: this machine is controlled by PLC controller, automatic warning and stop when any procedure get malfunction.
- Speed controlled by inverter.
- I-Mark control system for film.
- Automatically code printing system.
- Monolayer double multi-purpose packing.



Dimensions:

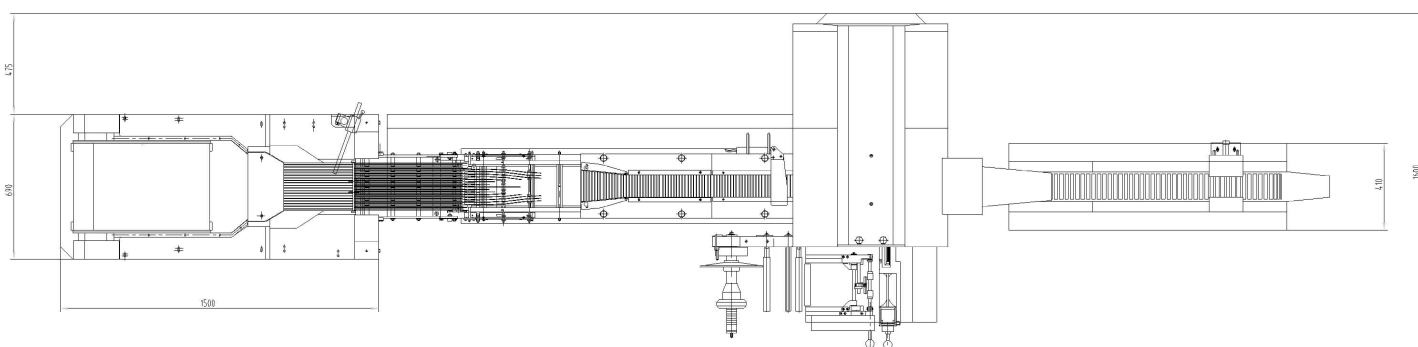
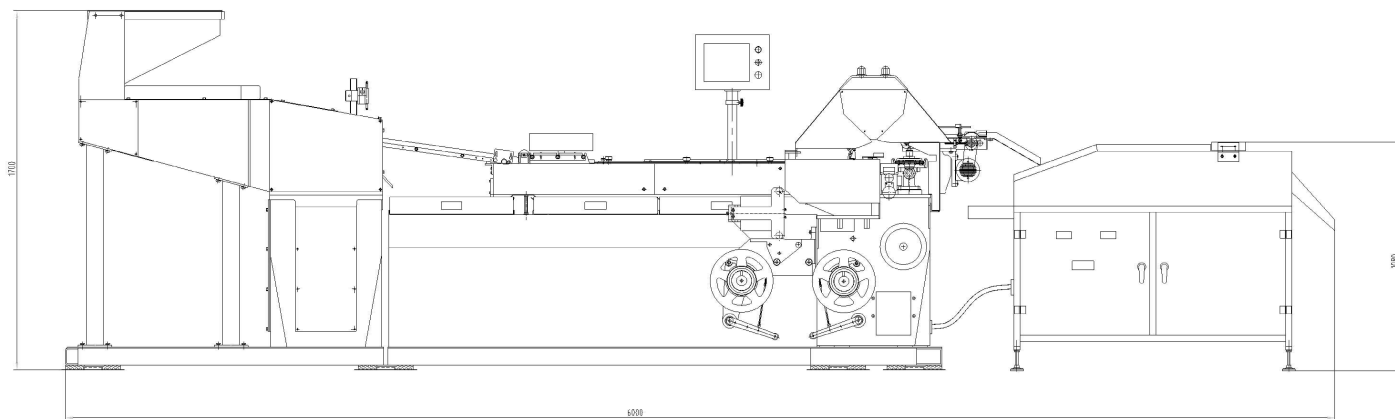

Technical specification	TR-150 for Tablet	TR-150 for Candy
Packing figure	Roll	Ellipse
Product size	Diameter: $\Phi 15-\Phi 25\text{mm}$ Thickness: 4-15mm Length of roll: 50-130mm	Diameter: $\Phi 17-\Phi 24\text{mm}$ Thickness: 6-12mm Length of packaging: 30-130mm
Packing speed	150roll/min	1000-2000pcs/min
Voltage	380V, 50Hz	
Power	3Kw	
Dimension (L x W x H)	5900 x 1650 x 1750mm	
Weight	1800kg	

SaintyCo also offer:

Encapsulation Solutions

Tablet Compression Solutions

Coating Systems

Cartoning Systems

Blister Packing Solutions

