



www.saintyco.com

MiniTab ST-8/ST-10

Rotary Tablet Press



MiniTab

Tablet press-bench top
-medium production



EASY
TO USE

UP TO
14400
TABLETS

UP TO
18000
TABLETS

A bench top rotary tablet press available in 2 main versions **ST-8** or **ST-10** (B&D version available upon request). The **MiniTab** has been designed and manufactured according to CE and GMP rules. It is used for R&D labs and pilot or small scale production batches. Easy to clean and simple to set up, it is designed to fit into a containment isolator systems. The unit can operate from 1 set to a full set of punches.

Models

MiniTab ST-8

MiniTab ST-10



MiniTab is a bench top rotary press developed to be used in R&D, laboratories and for medium production batches.

Available in 2 models:

ST-10: 10 stations handling punches up to 18 mm in diameter

ST- 8 : 8 stations handling punches up to 25 mm in diameter

- Turret made in stainless steel AISI 316 L (central section in contact with the product) and iron casting (upper and lower sections).
- Sturdy of compact design and with high versatility
- Independent weight and hardness adjustments
- The unit allows to operate from 1 to full set of punches
- Toolings are compatible with any B or D serie of International or European standard
- Speed adjustable from control panel
- Pre-compression
- Easy access to all parts of the machine through eight doors
- Quick tools change size in less than 30 minutes
- All parts in contact with the product are made in stainless steel AISI 316 L
- Machine manufactured to accomplish GMP rules and CE standard
- Electric parts on machine board

OPTIONS:

- Rotary forced feeder
- Suction aspirating pump

Combinations

POSSIBLE FILLING COMBINATIONS (OVER 30)

FLAT-FACED

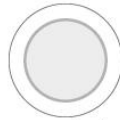
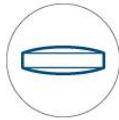

Standard

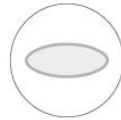

Oval



Triangle



Arc triangle

CAPSULE

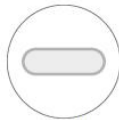

Capsule

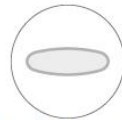

Modified capsule

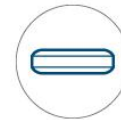

STANDARD CONVEX

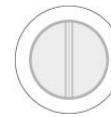
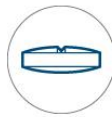

Bisect not flush



Quadrisect flush

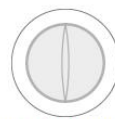

Straight through bisect



MODIFIED BALL

SHAPED CONVEX

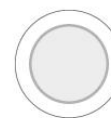
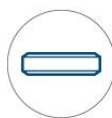
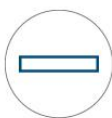

Plain

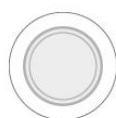

Bevel edged



Bevel edged bisect



Bevel edged quadrisect

Gallery



View of powder hopper and carousel

Pre-compression counter roller

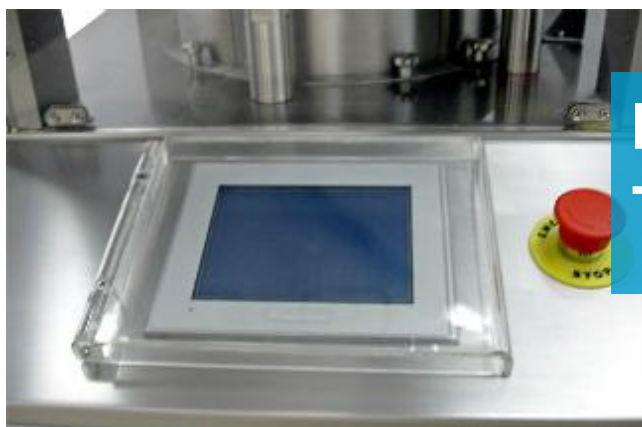

**PLC
Touch screen**

Technical Data

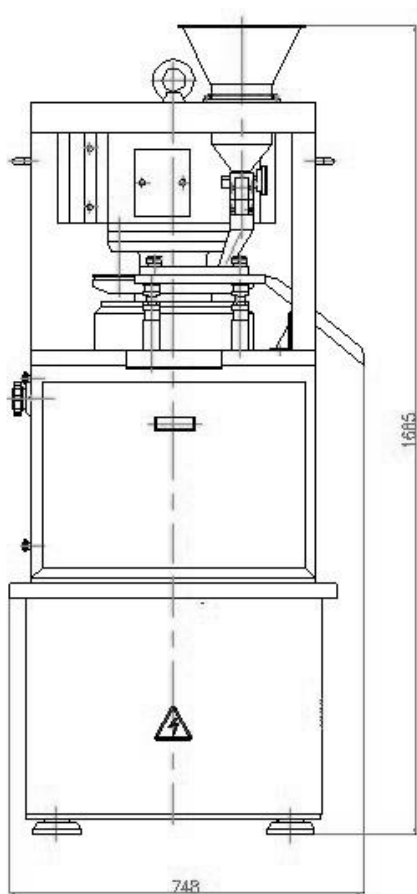

Technical Data	MiniTab ST-8	MiniTab ST-10
Stations number	8	10
Maximum tablet diameter	22mm	18mm
Pre-compression force	10KN	10KN
Maximum compression force	60KN	60KN
Depth of fill	16mm	16mm
Tablets/hour	14,400	18,000
Upper punch penetration	6mm	6mm
Feed	Open feed frame or forced feeder	
Tooling	D	B
Speed control	Inverter	
Main motor	380V 50/60HZ 2.2KW 3phase	
Net weight	650kg	
Gross weight	750kg	
Machine's dimensions	750×800×1685	

SaintyCo also offer:

Fluid-Bed Processors

High Shear Mixer Granulator

Roller Compactor

Blister Packing Solutions

