

FZB-100

Mini Type Conical Mill



Mini Type Conical Mill



FZB-100 Conical Mill for dry and wet processes in the pharmaceutical, food and related industries. Suitable for laboratory applications.

Features:

- Contact parts in SS316L and others in SS304.
- PLC + HMI control system.
- Tight particle size distribution, low fines, dust and overs.
- Low dust.
- Saving in containment/collector devices.
- Reducing the amount of dust in the environment.
- Low heat & temperature, suitable for milling heat-sensitive products.
- Design light and compact.
- Quick screen/ impeller change.
- Low maintenance.



Product Overview:

Conical mills are designed for milling processes in the pharmaceutical, food, chemical and related industries. The conical mill offers numerous benefits over alternative milling methods including higher throughput, tighter particle size distribution, easier cleaning/maintenance and less noise, heat and dust. They are suitable for a wide range of applications and offer full process scalability from laboratory to pilot to production.

Work Principle:

The machine utilizes the high-speed relative motion between the rotor and the sieve, which make the agglomerating materials granulated through the sieve pores under the crush of the rotor, and then the finished particles are discharged from the machine quickly with less heat, high efficiency and good quality. It adopts frequency conversion by which the main axis speed is adjustable within a wide range; also, it adopts under drive which enables the materials to be fed smoothly. The parts that contact the materials are made of stainless steel and the surface is polished and it can support the use of the wet granulator and the fluid bed dryer respectively. It is easy to be disassembled and cleaned, with no cross infection and meeting GMP standard.

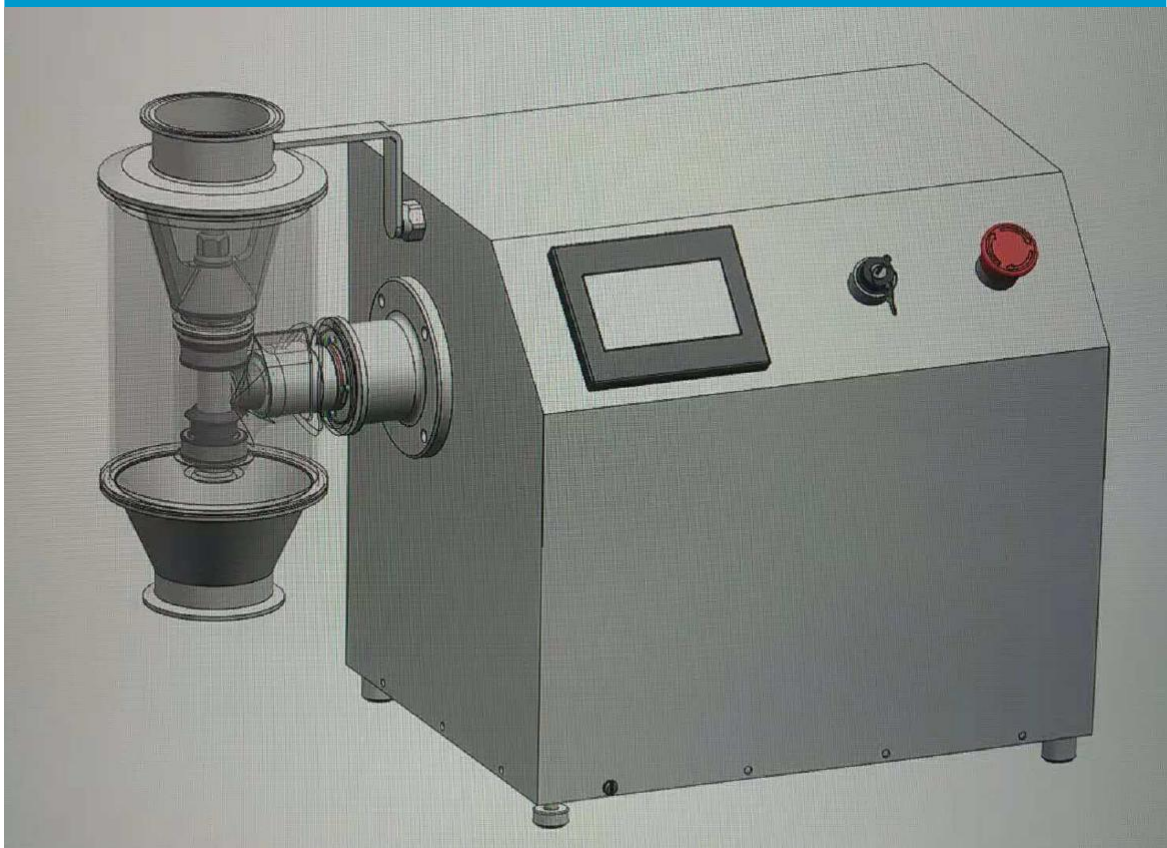

Detail image:

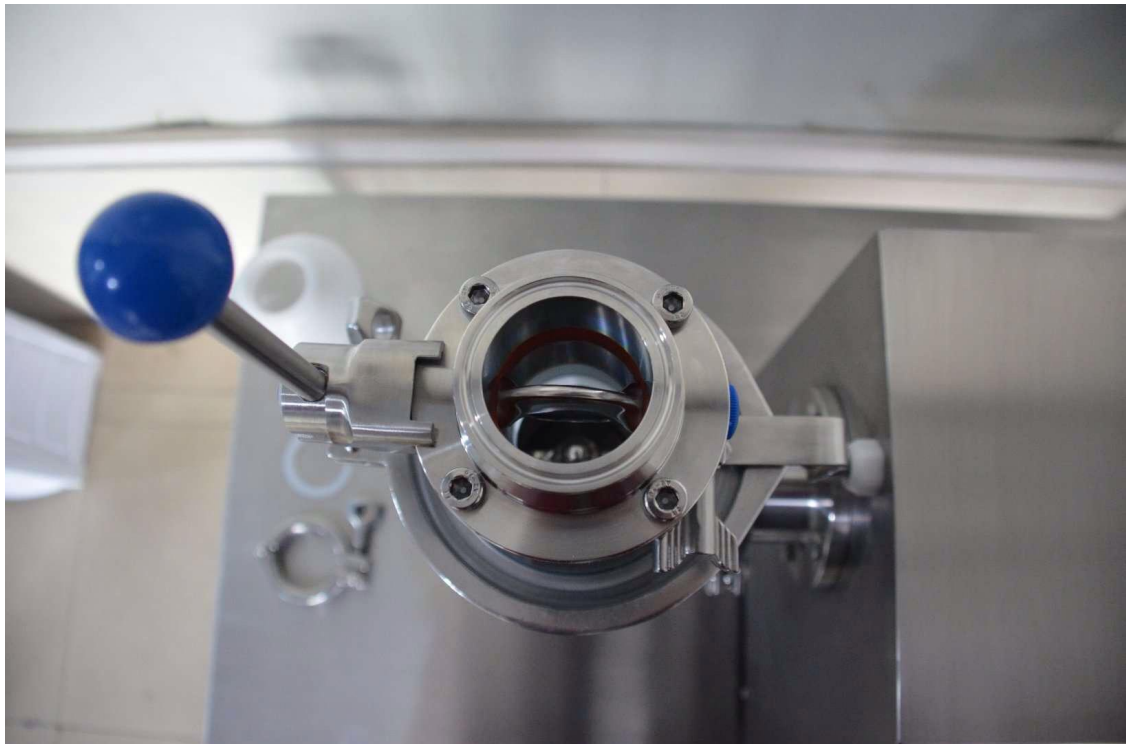

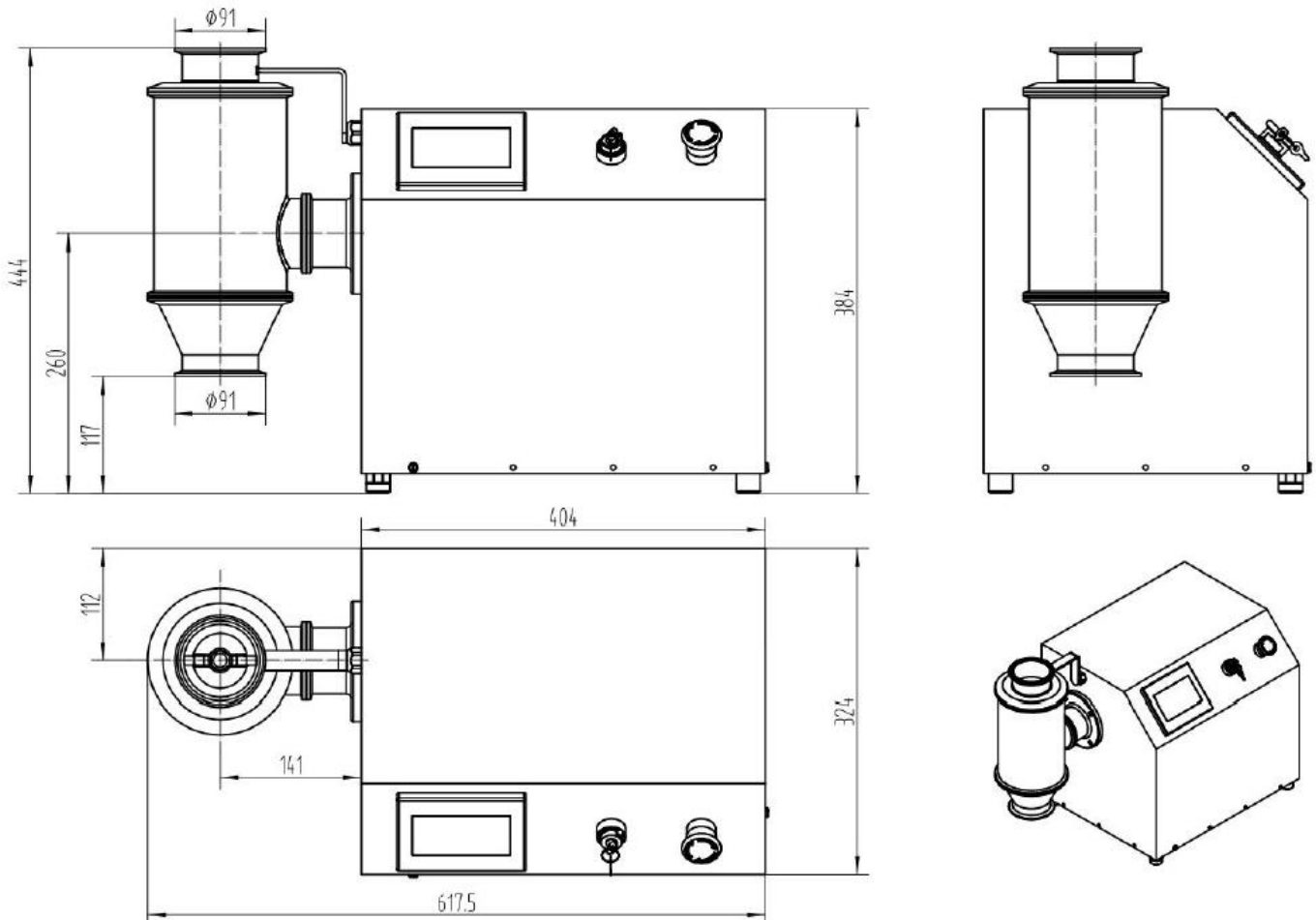

Model	FZB-100
Capacity	50 Kg/h
Max. Speed	3000 r/min
Power Supply	220V 50/60Hz
Motor power	0.75Kw
Dimensions	617.5×324×444
Weight	40Kg

SaintyCo also offer:

Encapsulation Solutions

Tablet Compression Solutions

Coating Systems

Cartoning Systems

Blister Packing Solutions

