

CVC1620 Tablet & Capsule Counter

- Lower Operating Costs

- Increase Operating Flexibility

- Unparalleled Service

- Quality that your Customers Demand

Solid Dose Bottling Lines

Blister Packaging
Cartoners
Labelers



- Touch Screen (optional)
- Picture shows double bottle discharge mode

The CVC1620 Electronic Channel Counter is designed for high speed, highly accurate counting of tablets, capsules, and soft gels. The machine comes standard with an automatic dust compensation system, dual vacuum ports, product count verification, and reject. The 1620 can be setup to run one bottle using all 16 channels or two bottles using 8 channels for each bottle. Options include touch screen industrial PC, hopper level control with tower Lamp, upside down bottle sensor, static eliminator bar, channel blocker, and floor loaded pre feeder.

- Built to cGMP Standards • Stainless Steel Construction • 50 Channels of Memory • Quick & Easy Change Over

"Leading Global Equipment Supplier"

www.cvcusa.com



CVC Technologies, Inc.

CVC1620 Technical Specifications

Standard Features:

- 16 V-Shaped Channels per head, tool less change over
- Auto Dust Compensation
- Dual Dust Extraction Ports
- Powered Height Adjustment
- Track Full / Track Empty Sensors
- 2.55M-Motorized Sanitary Conveyor
- Single or Double Bottle Discharge
- Pneumatic gating & plow reject for over / under count
- Memory capacity for 50 jobs
- Stainless Steel Construction
- Capacity:
 - Single Bottle Discharge: up to 70 bpm on a count of 100 products.
 - Double Bottle Discharge: up to 100 bpm on a count up to 90 products. Maximum Bottle Diameter= 65mm. Note: Actual rates based on product size, type, bottle count, and neck size.
- ISO 9001:2000 Certified

Product Specifications:

- Product Width / Diameter: 1/8" to 3/4" (3mm to 20mm)
- Product Length: 1/8" to 1-3/16" (3mm to 30mm)

Container Specifications:

- Bottle Height: 2" to 7-3/4" (50mm to 200mm)
- Bottle Diameter: 1-1/4" to 4-1/4" (30mm to 110mm)

Machine Specifications:

- FDA Approved Contact Materials
- Hopper Capacity: 30 Liters
- Machine Weight: 1,760 Lbs. (800kg) (not including conveyor)

Air/Electrical Requirements:

- Power Source: 220V, 50/60 Hz, Single Phase
- Power Consumption: 6 Amp
- Air Pressure: 87 psi (ISO 8573-1)
- Air Consumption: 7 cfm

Available Options:

- Hopper level control system with tower lamp
- Industrial PC, Windows XP, Touch Screen
- Static Eliminator Bar
- Container up side down or fallen sensor
- Channel Blocker
- Floor Loaded Pre-Feeder with Integrated Controls

Machine Layouts:

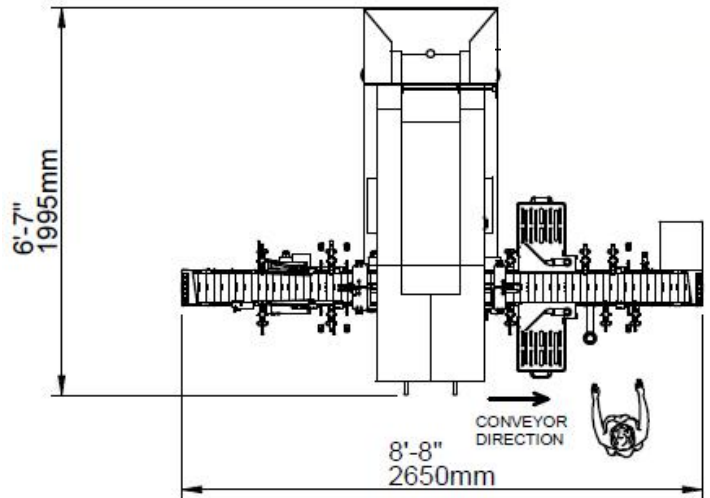

Top View

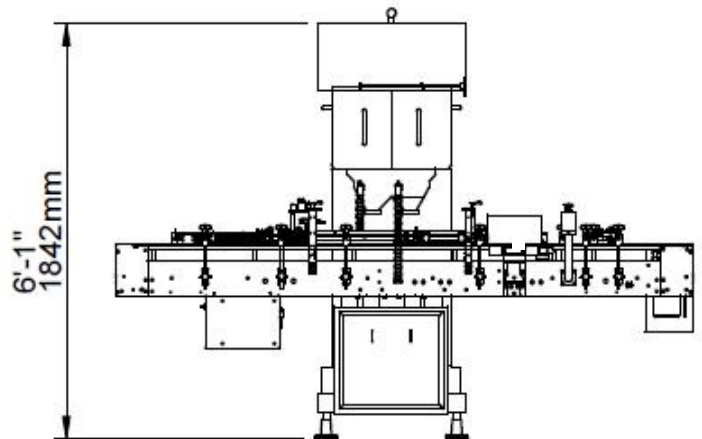

Front View



Authorized CVC Dealer

Copyright © CVC Technologies, Inc. • Jan. 2013 Edition

Dimensions shown are for a standard machine. The 1620 Counter must be purchased with integrated conveyor as shown. This machine can run independently or can be integrated into an automated packaging line. All CVC equipment is covered by a one year parts warranty. Full Warranty details are included in our equipment proposals or can be found on our website.