



## STAINLESS STEEL VERTICAL BUCKET ELEVATOR



Stainless Steel Vertical Bucket Elevator, Model VB-18-6-2LSS

- Stainless Steel Sanitary Construction, 90-Degree Angle
- High Level Sensor Controls to Automatically Start/Stop Product Flow into the Weighing Machine
- Automatic and Manual Controls
- Food Grade Bucket—Flat Or Dimpled
- Tool-Less Removal of Buckets
- Tool-Less Removal of Discharge Chute
- Plastic Drive Sprockets with Stainless Steel Bearing
- Stainless Steel Drive Chain
- Capacity: 4 liter model = up to 600 liters per minute
- Capacity: 2 liter model = up to 400 liters per minute
- Easy To Operate & Easy To Clean
- Access Door At Ground Level, Both Front & Back
- Third Access Door Underneath Top Feed Area
- Safety Interlock Switches On Ground Level Doors
- Casters For Easy Positioning

ELECTRICAL REQUIREMENTS:  
 A. (1) 10A 220VAC 3 PHASE @ 60 HZ

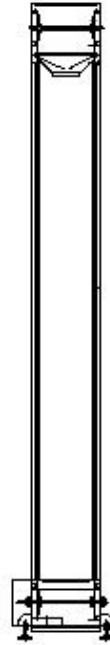
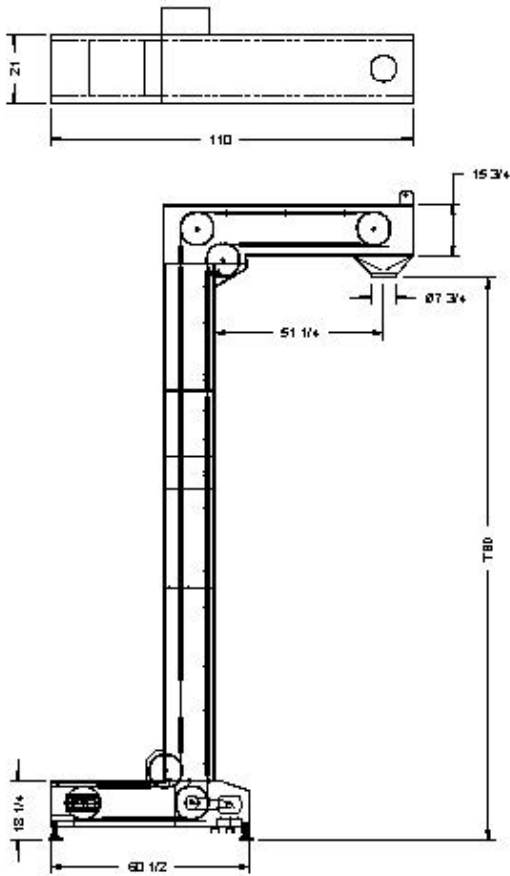

DRAWN	1/2/51/2013	Ohlson Packaging	
DESIGNED		TITLE	
QA		BUCKET ELEVATOR 2L	
PTG		REV	CUSTOMER NAME
APPROVED		A	STANDARD
ALL DIMENSIONS IN INCHES	SCALE		SHEET 1 OF 1