

E-11 Jar and Bottle Labeling Machine

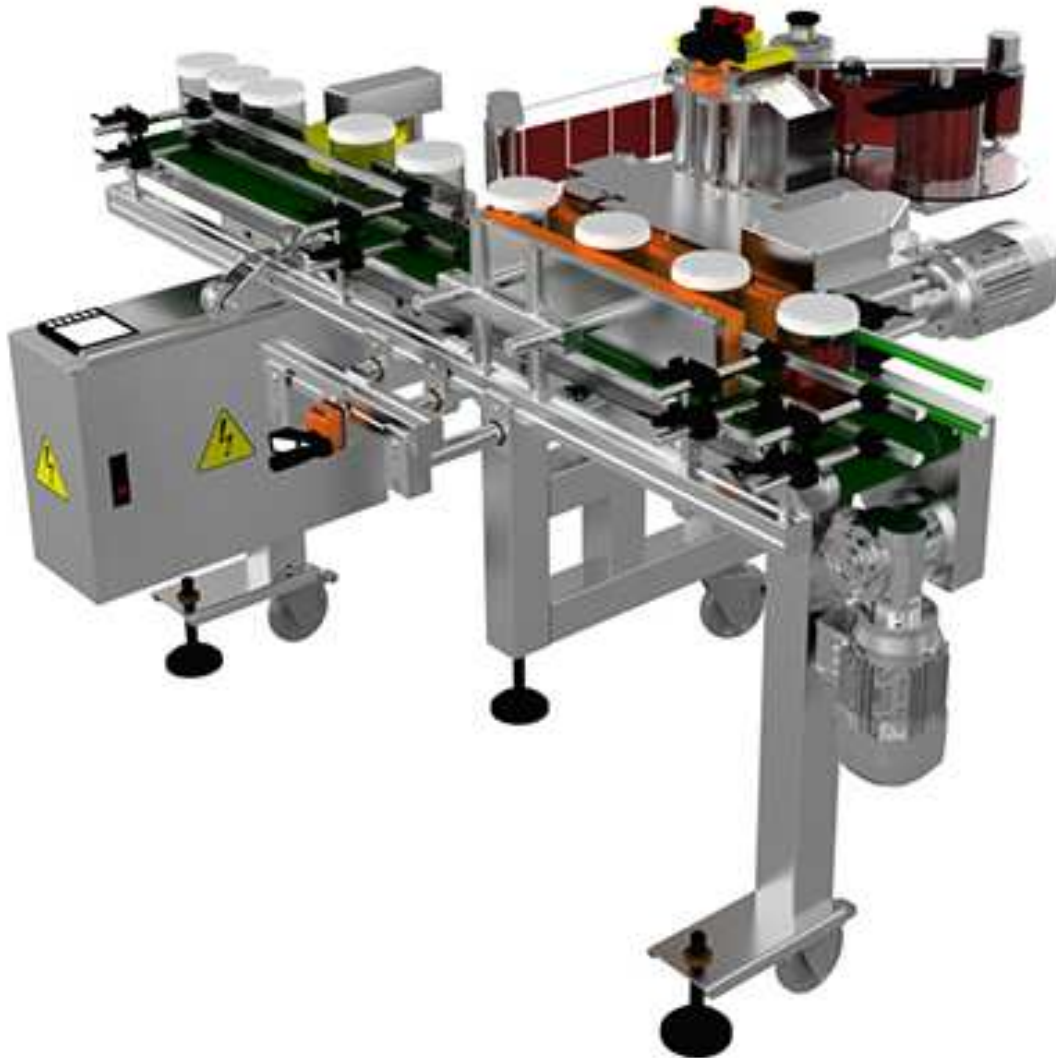

TECHNICAL SPECIFICATIONS

- * Labels cylindrical, square and hexagonal packages on one side or all-around.
- * Easy adjustments by the hand wheels and numerators.
- * No change parts required for different shapes/ sizes of packages.
- * Quick change –over from one product another.
- * Functional & robust.
- * Flexibility for wide range of packages for now and in the future.
- * Can dispense labels min. 8 mm- max. 128 mm in width (optional dispense form in. 8 mm- max. 248 mm)
- * Specific photocells for transparent labels.
- * 20 meters/minute label dispensing speed

