

Bench Top Blender

HSD Series



Bench Top Blender

HSD series Bench Top Blender is mainly used in laboratory solid preparation for mixing of granules and granules, granules and power, powder and powder. Meanwhile, it is widely used in pharmaceutical, chemical and foodstuff industries.



LDS Pharma Bin



Principle:

This equipment is composed of frame, drive and control systems, and fixed mixing bin, etc. When operating, charge the materials and lock the bin lid. Set the mixing time and speed, start the control system to execute the operation. On reaching the set time, the fixed bin stops being a horizontal position and the mixing task is finished.

Features:

- Suit for R&D.
- High efficiency mixing.
- Small footprint.
- Movable design.
- Detachable bin design for various batch size application.
- Efficient blending.



Dimensions:

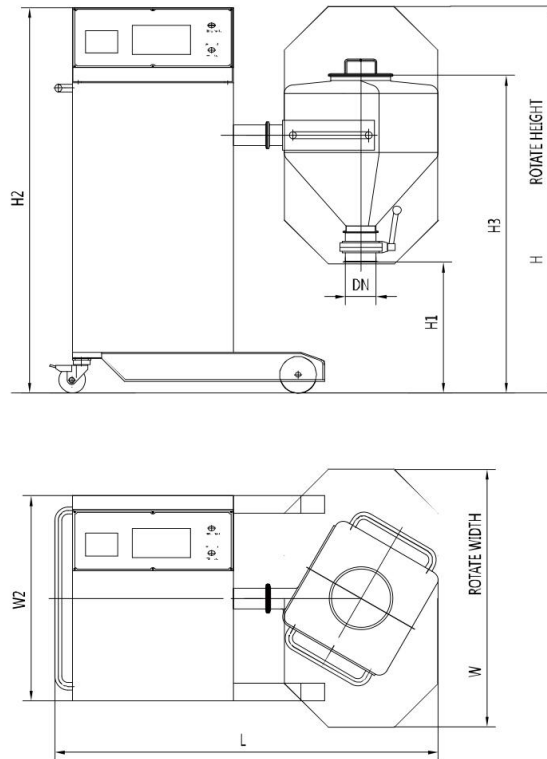

Technical Data	HSD5	HSD10	HSD15	HSD20	HSD25	HSD30	HSD50	HSD75
L	920	1010	1010	1090	1090	1090	1310	1310
W	570	650	650	700	700	700	880	1050
W2	450	450	450	450	450	450	700	700
H	1000	1050	1050	1050	1050	1050	1320	1400
H1	470	410	410	360	370	370	440	370
H2	980	980	980	980	980	980	1315	1315
H3	830	800	880	820	880	925	1085	1150
DN	50	50	50	75	75	75	100	100
Blending speed(rpm)	3-25							
Max bin volume(L)	5	10	15	20	25	30	50	75
Loading volume(L)	4	8	12	16	20	24	40	60
Loading weight(Kg)	2.5	5	7.5	10	12.5	15	25	37.5
Total power(kW)	0.25	0.25	0.25	0.25	0.55	0.55	0.55	0.75
Total Weight(Kg)	150	160	170	180	185	190	200	230

SaintyCo also offer:

Encapsulation Solutions

Tablet Compression Solutions

Coating Systems

Cartoning Systems

Blister Packing Solutions

