

## High Speed Chocolate Packaging Machine (F-SNZ800)

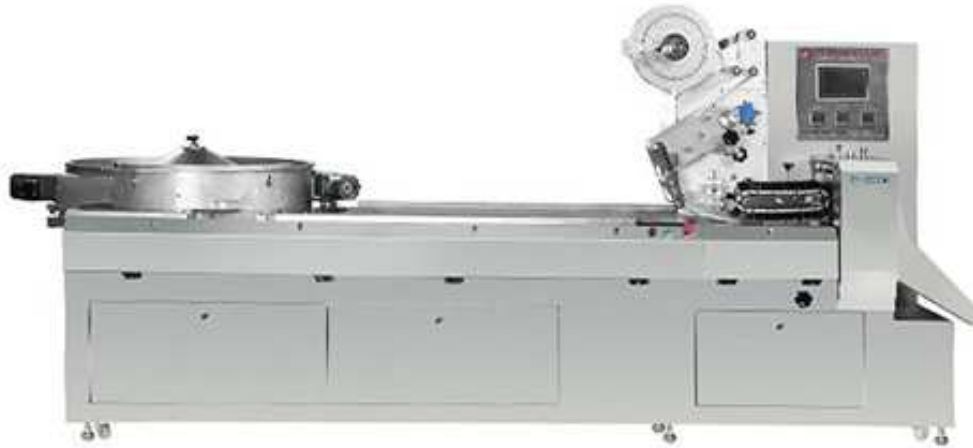

### Main Features:

With advanced servo-motor intelligent control system, it can reduce the multi-function rate and run stably with low noise.

It can be connected directly with the production line and can achieve the automation of feeding, forming, filling and saving labor force.

With intelligent human-interface design and touch screen. It can show the machine working condition clearly and ensure the easy operation of the machine.

With automatic inspecting system and achieves the packing rate of 100%. Without empty packing.

### Technical Parameters:

Packing Speed	50-500 pcs/min
Product Shape	Square, Rectangle, Trapezoid and Hemicycle
Packing Range	12-50(L)*10-28(W)*6-20(H)mm
Total Power	6.8kw
Machine Dimension	5730*1650*1520mm
Total Weight	2580kg
Voltage	380V,50HZ
Packing Materials	OPP, CPP, PET, aluminum plating film, any hot sealing film