



Focus Labeling Machine

HPLM-A High Speed Rotary Labeler



This machine is in rotary labeling way for round shape products, specially suit for the company with high production, labeling speed can be 300-500pcs / min.

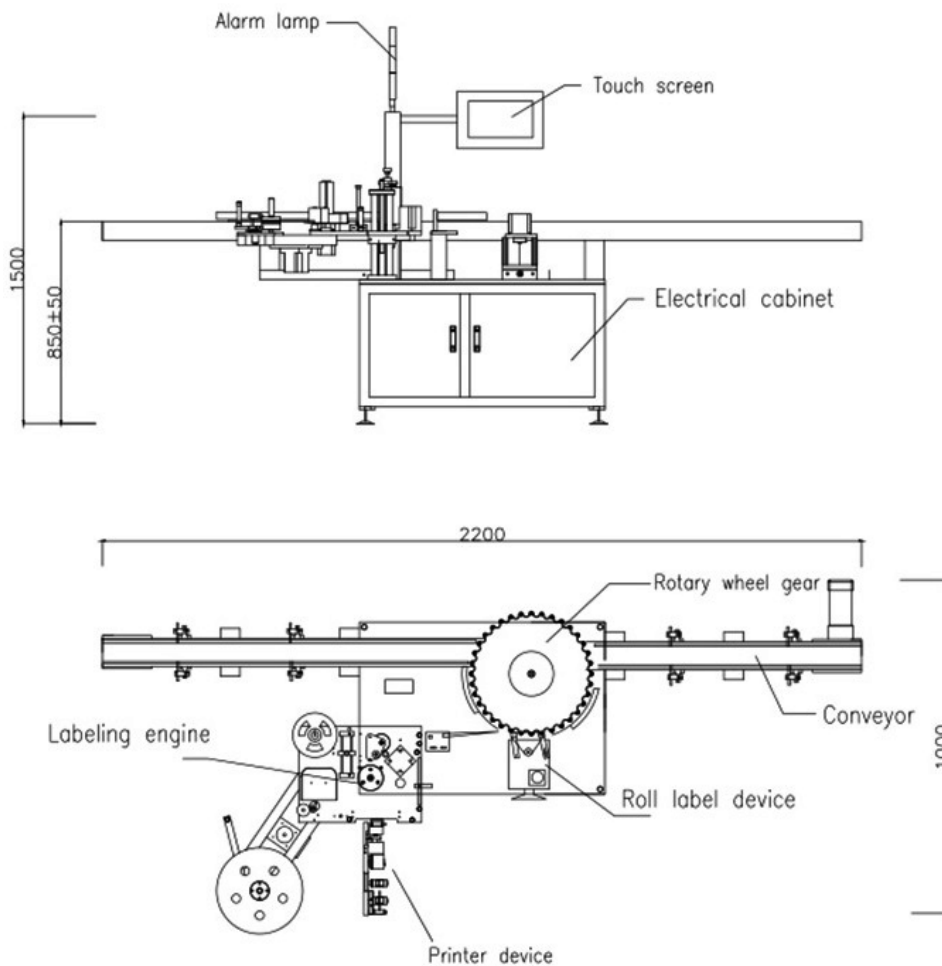

Parameters

Model	HPLM-A
Driving Mode	Servo motor
labeling methods	The bottle is stand into, stand labeling, stand out
Conveyor Speed (m/min)	≤40
Labeling Accuracy	±1.0mm
Label material	Adhesive sticker, opaque or transparent label
The inner diameter of label roll	76 mm
The outer diameter of label roll	350 mm(max)
The size of bottle	Outer diameter 20-100mm, height 25-200mm
The size of label	Height 20-180 mm length 25-200 mm
Printer to use air	5kg/cm ²
Voltage	AC220V 50/60HZ Single side (Can customized as buyer need)

