

F

luid-Bed Dryer for Lab

Mini FBG Series



Fluid-Bed Dryer for Lab

Mini FBG integrates top spray granulation and bottom spray coating functions in one unit with 50-200g small capacity. It is ideal lab equipment for formulation development in R&D.



Features:

- Multi-functional lab unit
- Mini means small size and capacity.
- With top spray and bottom spray functions.
- Metal filter blowback clean cartridges
- Each parts can be mounting and dismounting very easily.
- Intelligent control.
- Process data printable.



Dimensions:

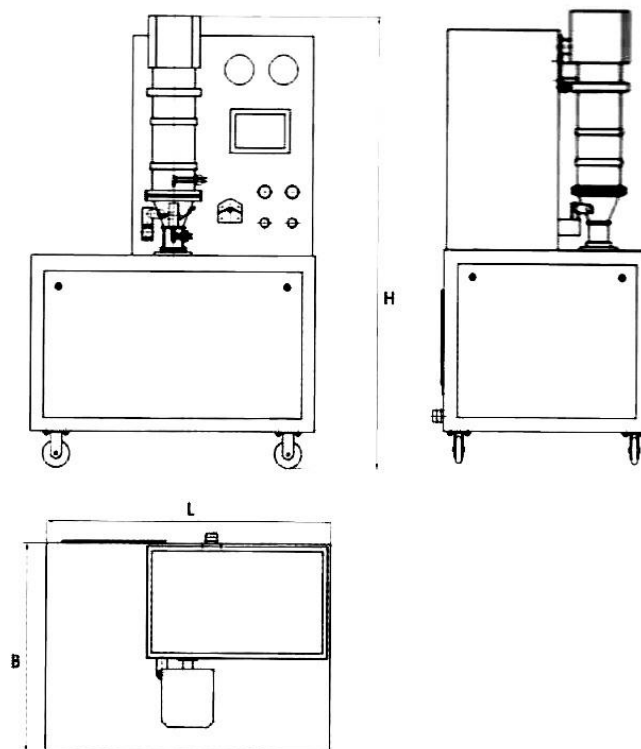

Technical Data	Mini-FBG
Productive capacity	50-200g
Volume flow	0.8m ³ /min
Pressure	0.02Mpa
Power	220V/50Hz
Blower	0.75Kw 2900r/min
Heater	15~120℃ 0.5-1Kw
Compression air	0.4-0.6 m ³ /min 0.15Kw
Motor	0.18Kw 2100r/min
Dimension(L×B×H)	700×700×1000
Weight	92Kg

SaintyCo also offer:

Encapsulation Solutions

Tablet Compression Solutions

Coating Systems

Cartoning Systems

Blister Packing Solutions

