

## *Ohlson Supply Hopper*



**Supply hoppers allow for the steady flow of product onto a conveyor, bucket elevator, weigher, or other pieces of the packaging process, and are often integrated into weighing and filling systems.**

**Hopper Size: Five Cubic Foot Standard (10, 15, and 20 cubic foot sizes available)**

- **Stainless Steel Construction—Flat or Dimpled**
- **Electromagnetic Feeder**
- **Variable Speed Control to Regulate Flow Easily**
- **Easy to Operate & Easy to Clean**
- **Single or multiple output**
- **Available conveyORIZED feature (Required for sticky gummies)**
- **Pneumatic Bin Hopper also available for non-free flowing products or products which require gentle handling**
- **Perforated pan (can removed un-popped popcorn kernels or other small debris)**
- **Stainless steel mesh cover**
- **Support frame for super sacks**

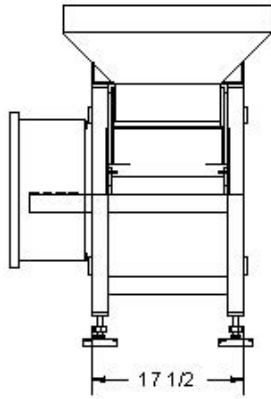
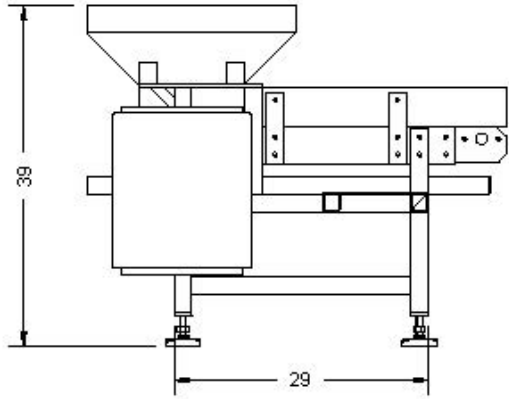
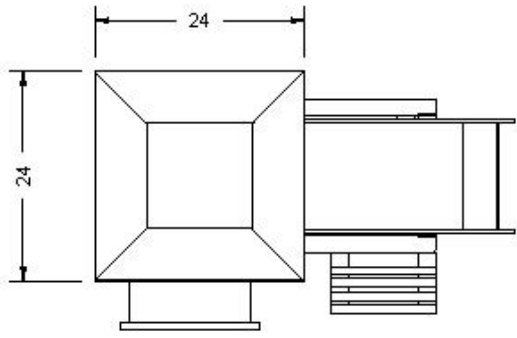

DRAWN F. CHARRON	1102201	
SPECIFIED		
DATE		TITLE
APPROVED		CONVEYORIZED SUPPLY HOPPER
DATE		SUB C
DESCRIPTION IN INCHES	SCALE	CUSTOMER NAME SH-5C
		REV A
		SHEET 1 OF 1

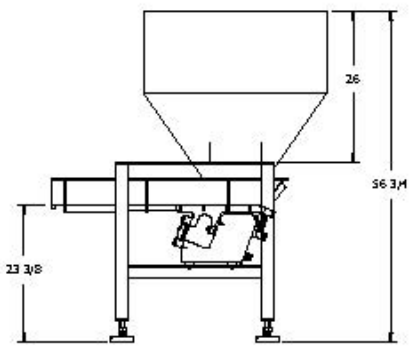
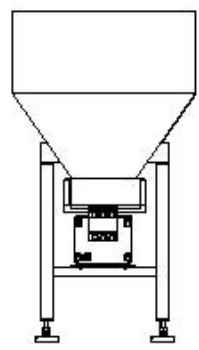
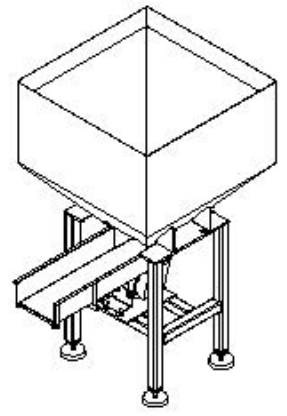
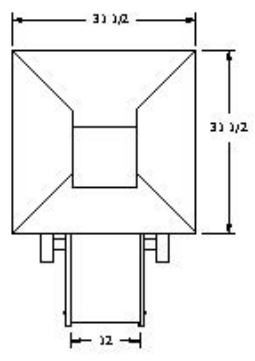

**ELECTRICAL REQUIREMENTS:**  
A. (1) 10A 115VAC SINGLE-PHASE @ 60HZ

DRAWN F. CHARRON	01111201	
SPECIFIED		
DATE		TITLE
APPROVED		SUPPLY HOPPER, 10 C.U. FT.
DATE		SUB C
DESCRIPTION IN INCHES	SCALE	CUSTOMER NAME SH-2-SS-XL
		REV A
		SHEET 1 OF 1