



Focus Labeling Machine

PWM-A Horizontal Way Labeler



This machine is suit for small round objects which can not stand stably when labeling, such as ampoule, injection, penicillin, pen, battery, tubes and so on, machine conveyor is custom made depends on client product size.

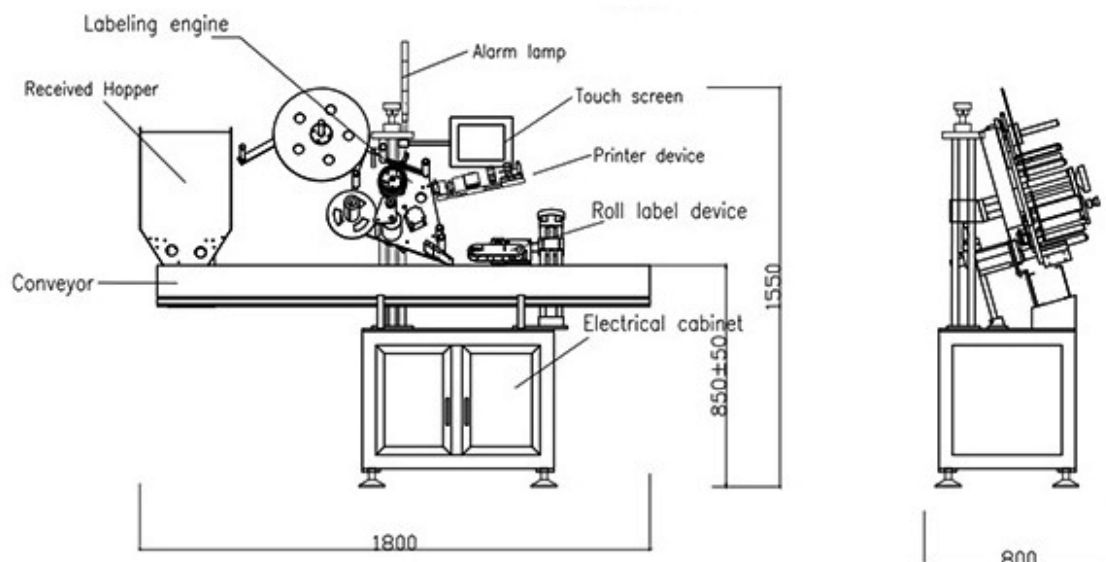

Parameters

Model	PWM-A
Driving Mode	Servo motor
Yield(pcs/min)	30-200
Operating direction	Left or Right
Conveyor Speed(m/min)	≤40
Labeling Accuracy	±1.0 mm
The inner diameter of label roll	76 mm
The outer diameter of label roll	350 mm(max)
The suitable size of label	Width 15-100 mm length 15-80 mm
The suitable size of labeling objects	Customized depends on client product
Printer use air	5kg/cm ²
Power(w)	600W
Weight(kg)	200
Machine size	1800(L) 800 (W) 1500 (H) mm

