

LR-250X

CYLINDER LABELING MACHINE

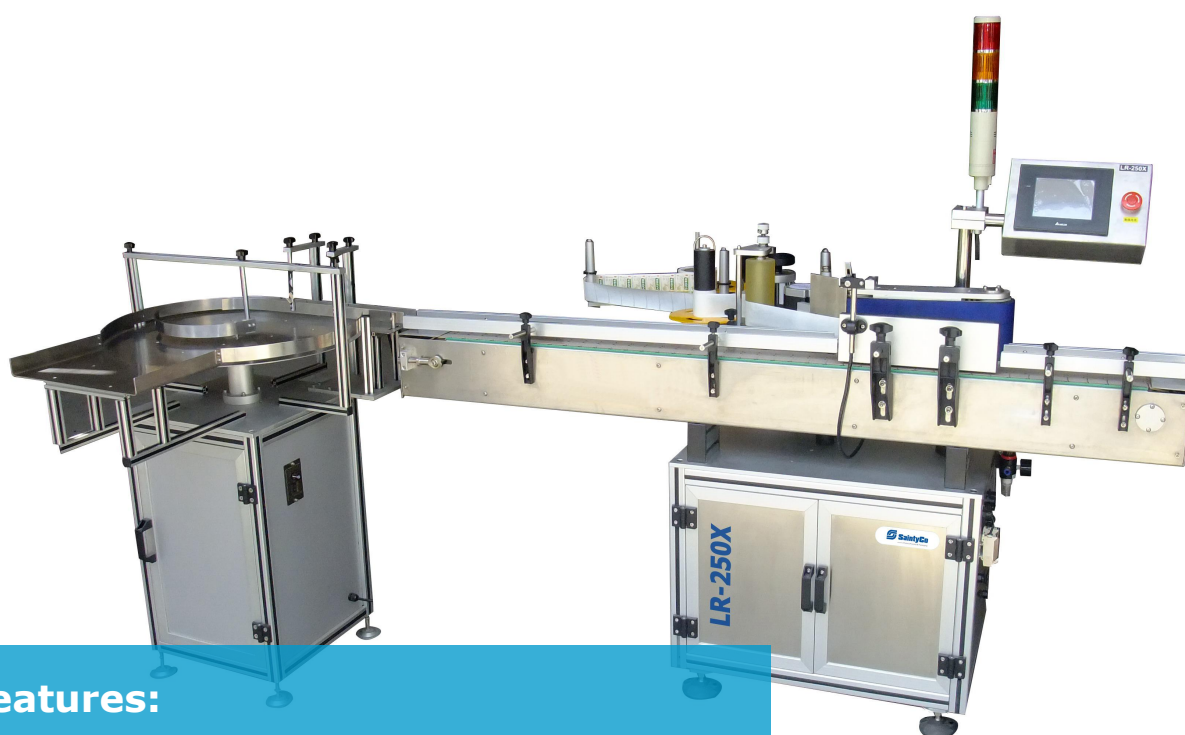

CYLINDER LABELING MACHINE



Features:

- This labeling system is equipped with stepper driven(Taiwan technique)for allows stable torque when around-the-clock operate consistently.
- Programmable logic Control system integrated with user-friendly touch screen interface panel which is both versions selected of English and Chinese, as well as illustrated display for operate ef-fortless.
- The machine used container-space to feeding bottles for allows stable labeling and apply the label on all kinds of round container in semi-or fully wrap-around.
- Optional includes hot stamping date coder to coding Lot No., MFG date and Expiry date...etc.

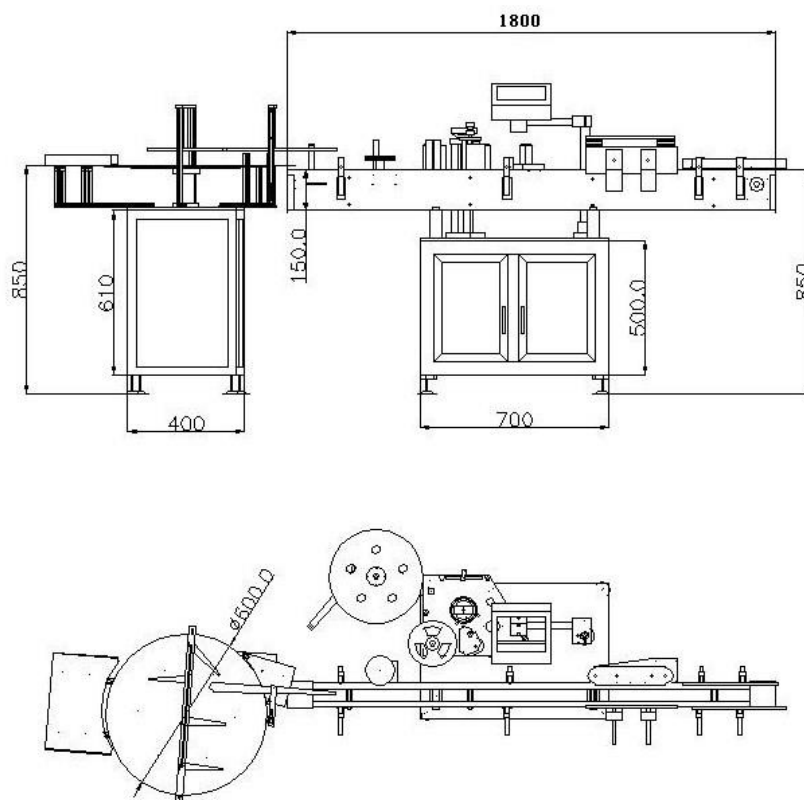

Technical Data	LR-250X
Capacity	50-130 bottles/min
Label length	10-300mm
Label width	10-100mm
Accuracy	± 1 mm
Label roll	Max 320mm \varnothing
Label core	Stander 75mm \varnothing
Machine size	1800(L) \times 1000(W) \times 1600(H)mm
Power	AC 220V
Air consumption	4-6Kg
Weight	300kgs

SaintyCo also offer:

Encapsulation Solutions

Tablet Compression Solutions

Coating Systems

Cartoning Systems

Blister Packing Solutions

