



# Focus Labeling Machine

## DPM-W Top Labeler with out Conveyor



This machine also labels on product top surface. The advantage is can put on client production line or packaging line very conveniently with out conveyor.

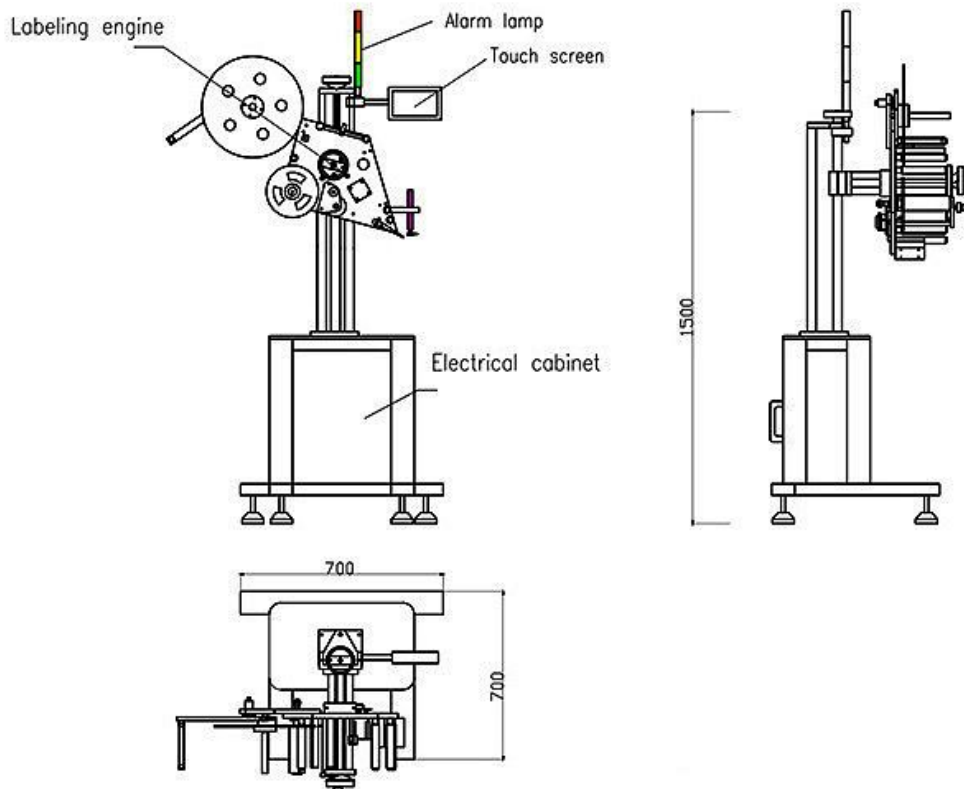

## Parameters

<b>Model</b>	<b>DPM-W</b>
Driving Mode	Servo motor
Operating direction	Left or Right
Conveyor Speed(m/min)	≤40
Labeling Accuracy	±1.0 mm
The inner diameter of label roll	76 mm
The outer diameter of label roll	350 mm(max)
The suitable size of label	Width 15-300 mm length 15-300 mm
The suitable size of labeling objects	Can customized depends on client product
Printer use air	5kg/cm <sup>2</sup>
Voltage (In China)	AC220V 50/60HZ Single phase (Can customized as client need)